

TROLL STATION

ANTARTICA 72°00'42"S, 2°32'06"E

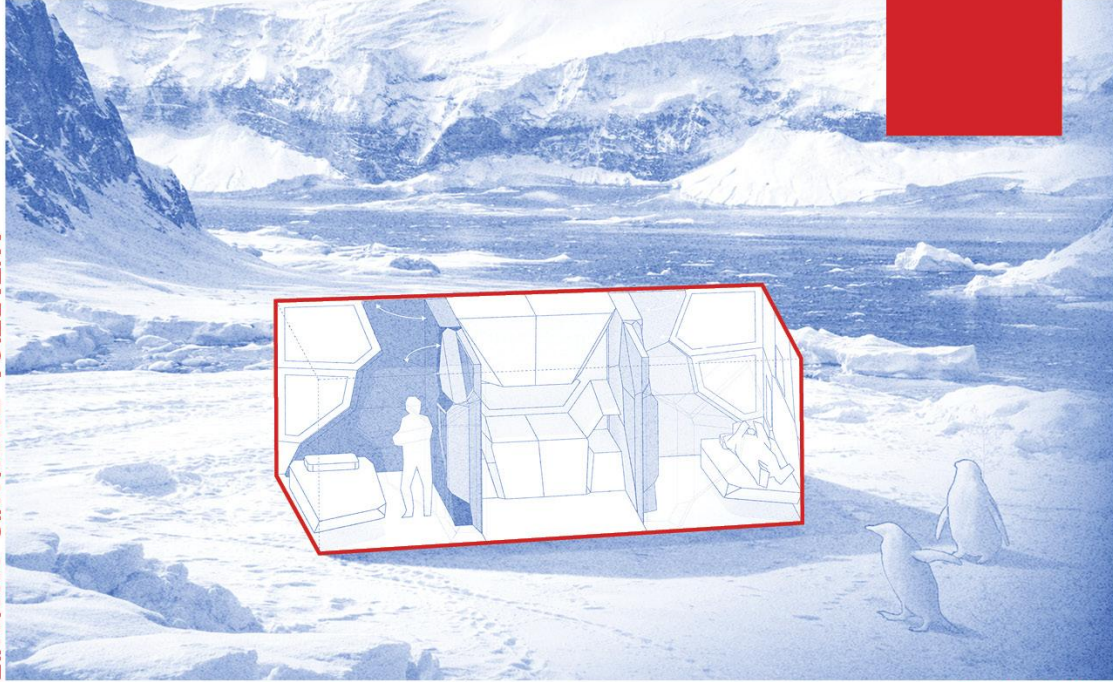

2026 - MS-c2 - Q3

GROUP 4
ANAELLE MATHIEU
AASHNA SINGH
ILAI DEBAZI
LUCA MARCHETTI
SOHYUN PARK
NIELS KOENRAAD

1:1 IAP



Form creation

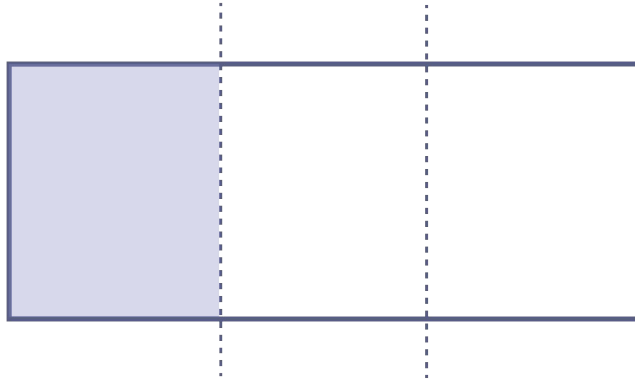

GRASSHOPPER LOGIC

ITERATION 01

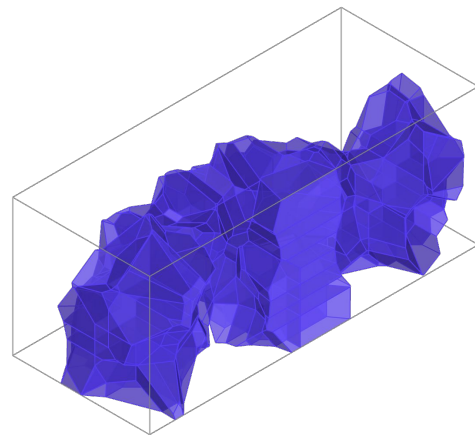
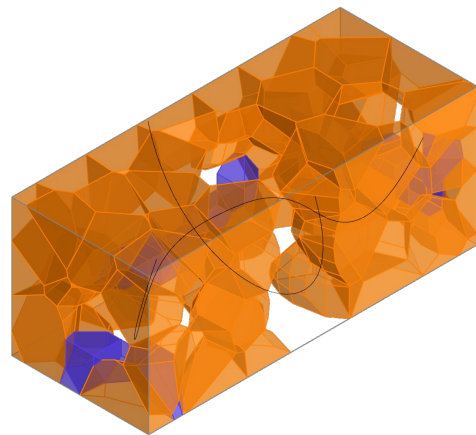
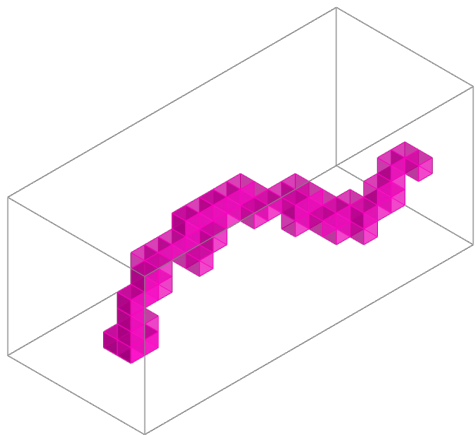

ITERATION 02

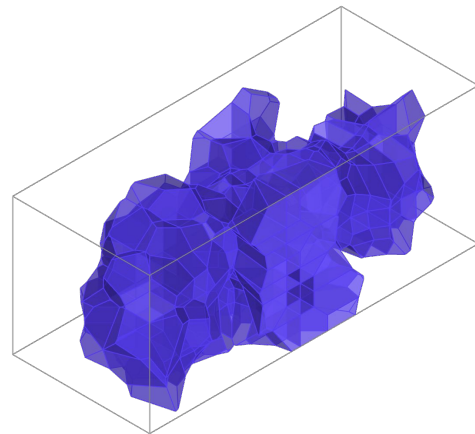
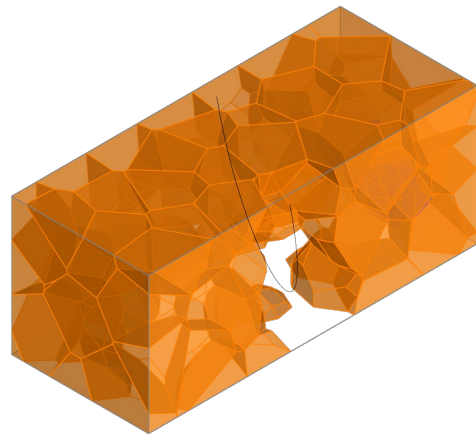
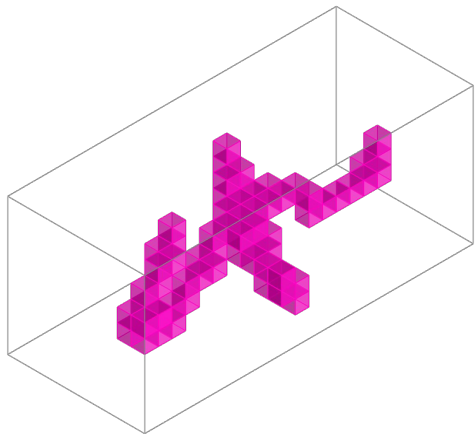

ITERATION 03

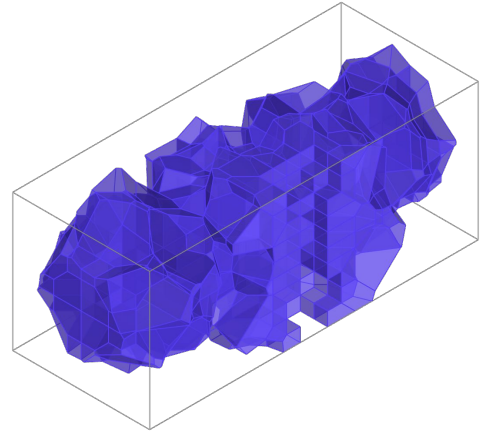
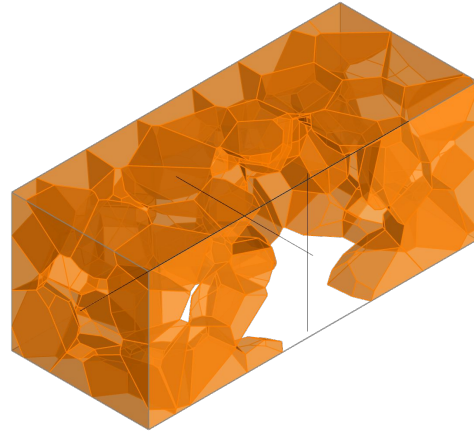
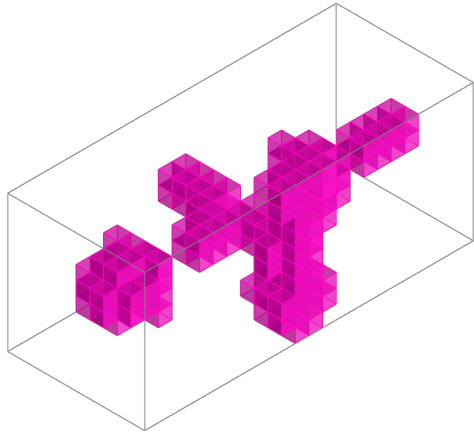

ITERATION 04

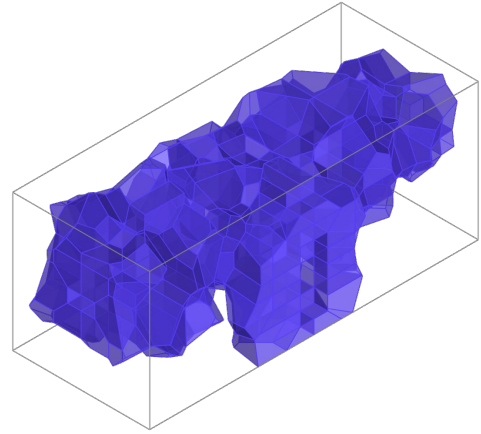
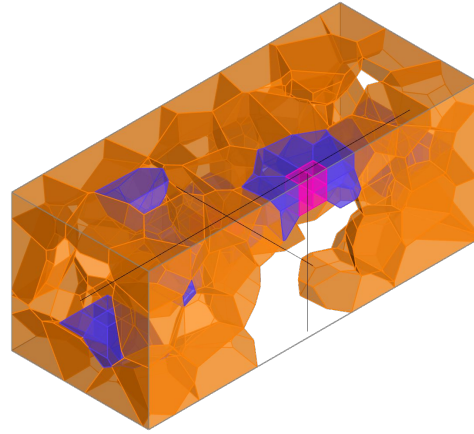
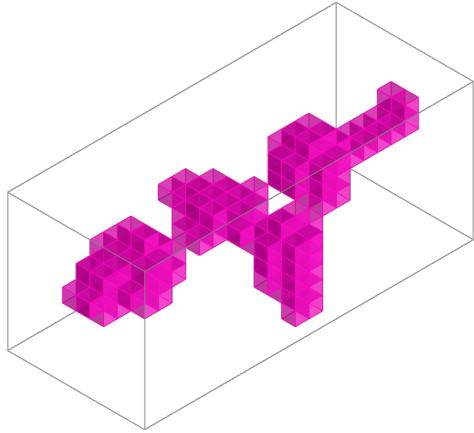

ITERATION 05

Concept of the iteration

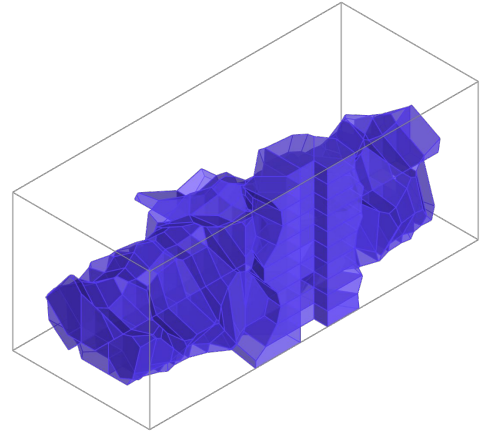
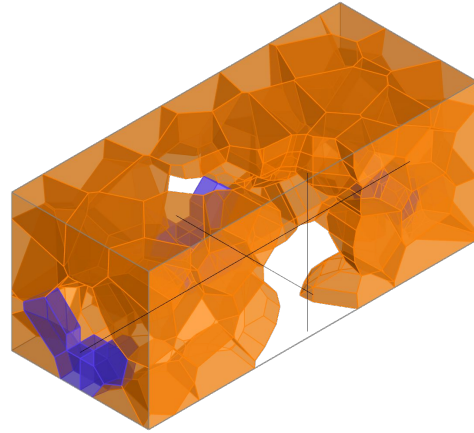
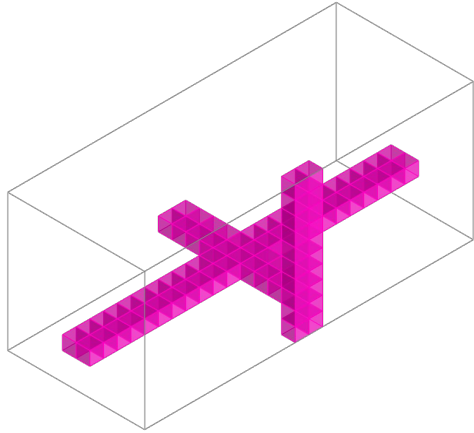

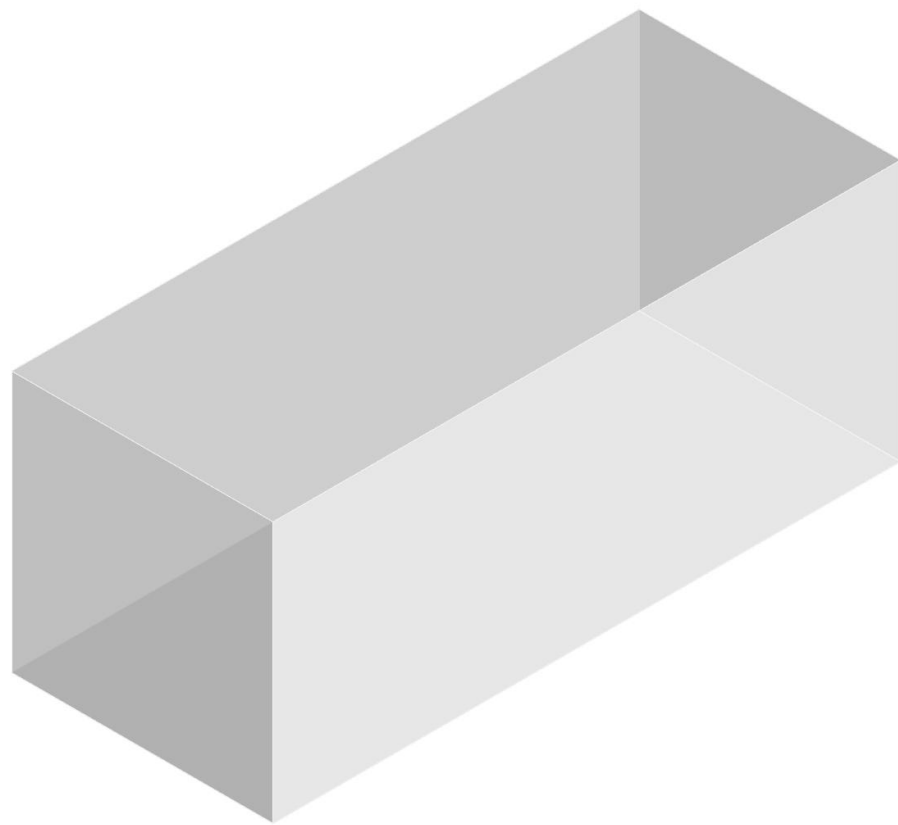

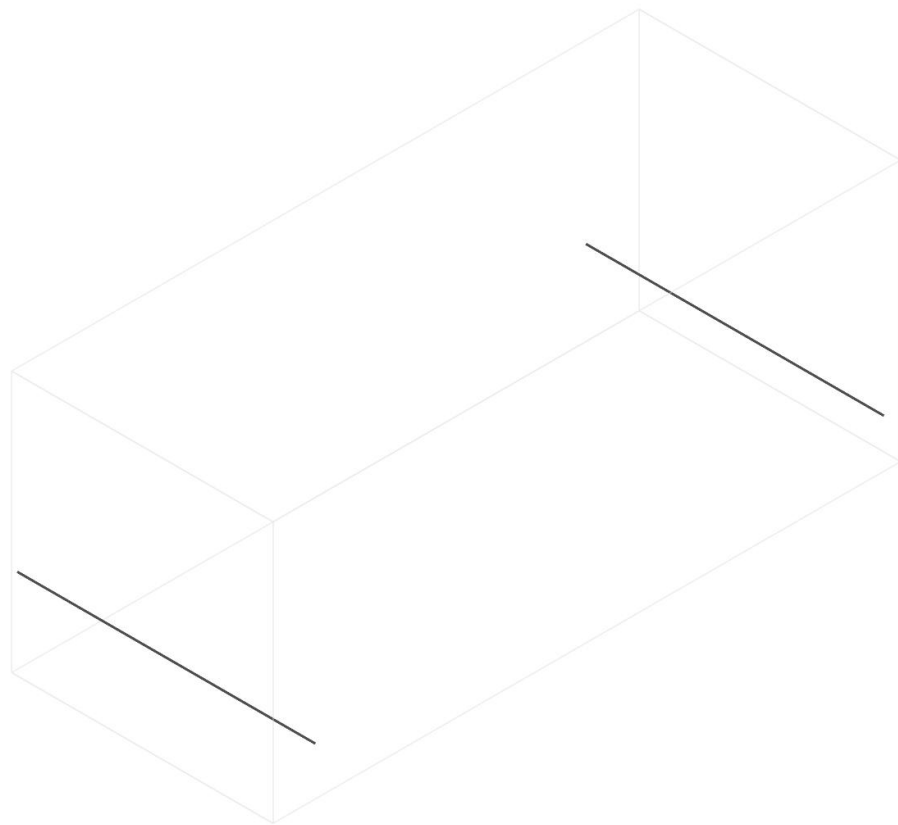

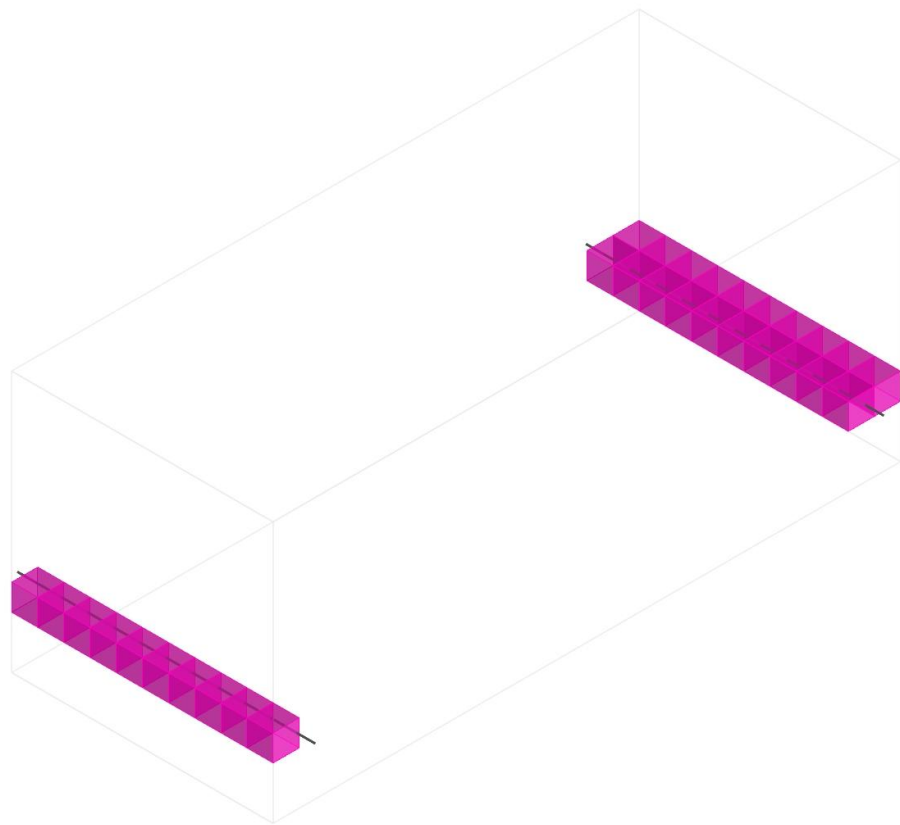

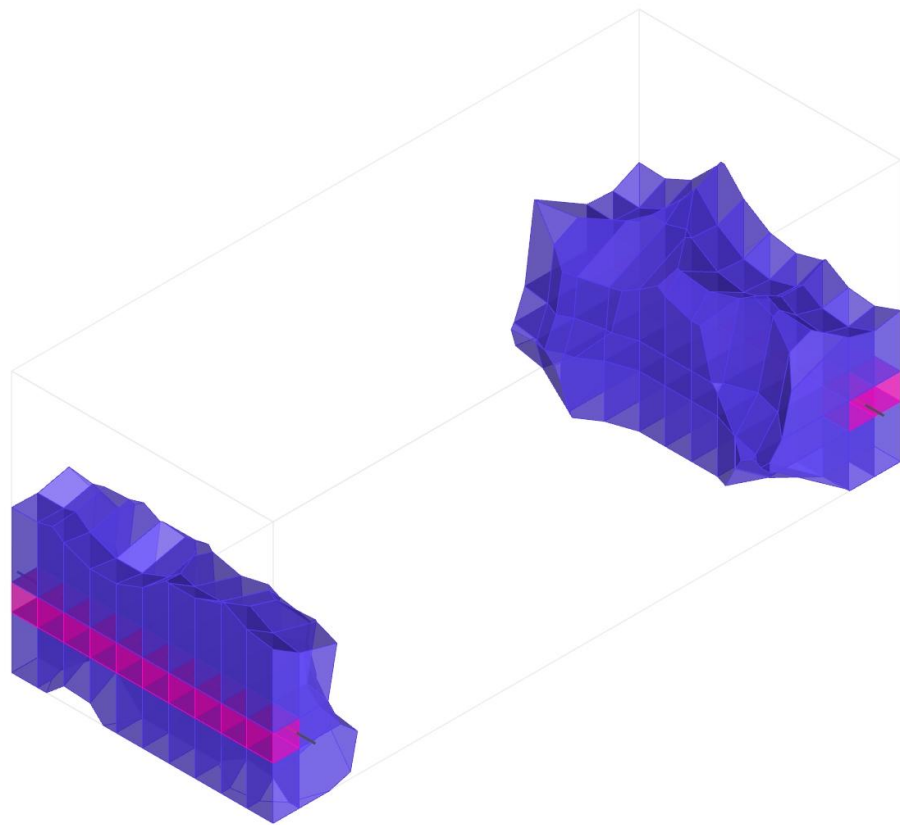

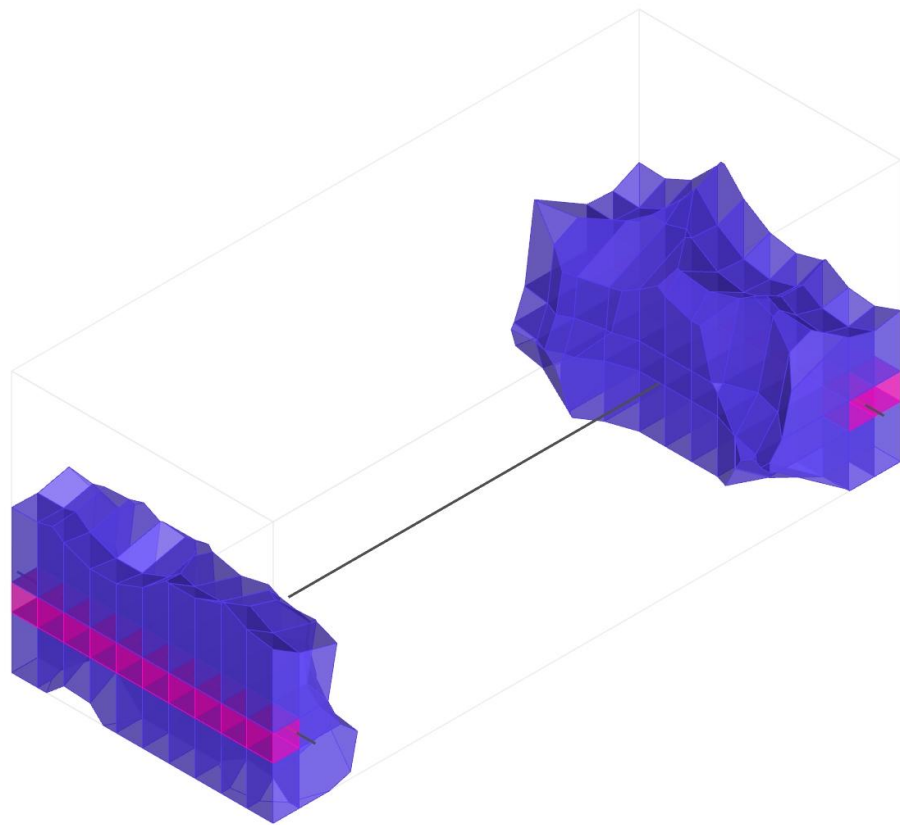

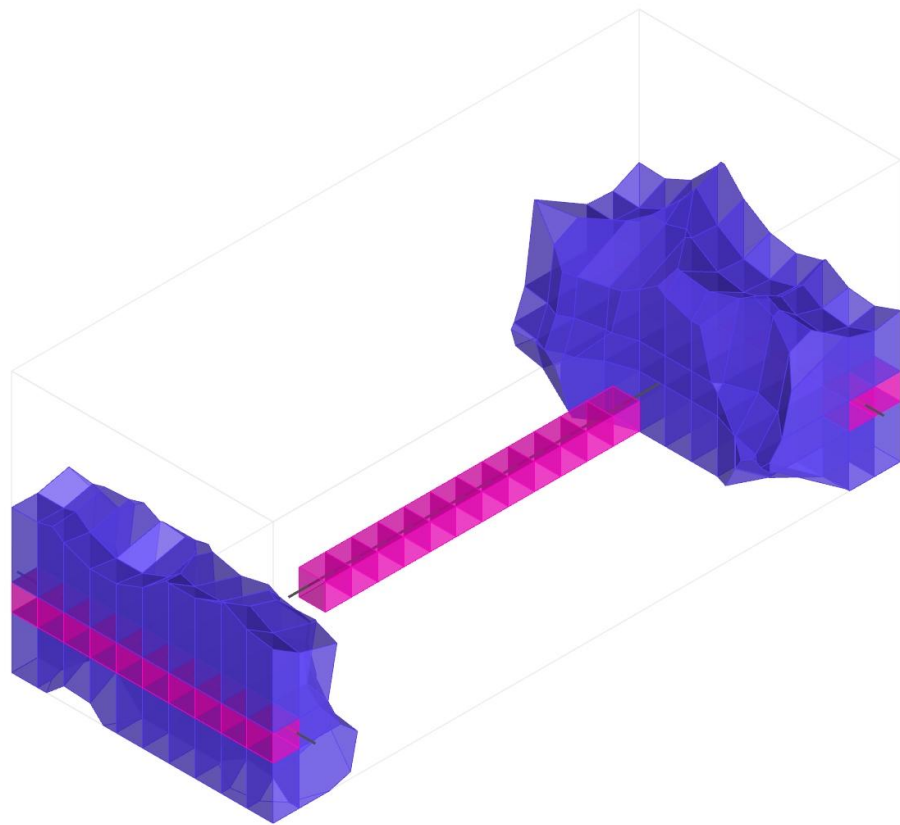

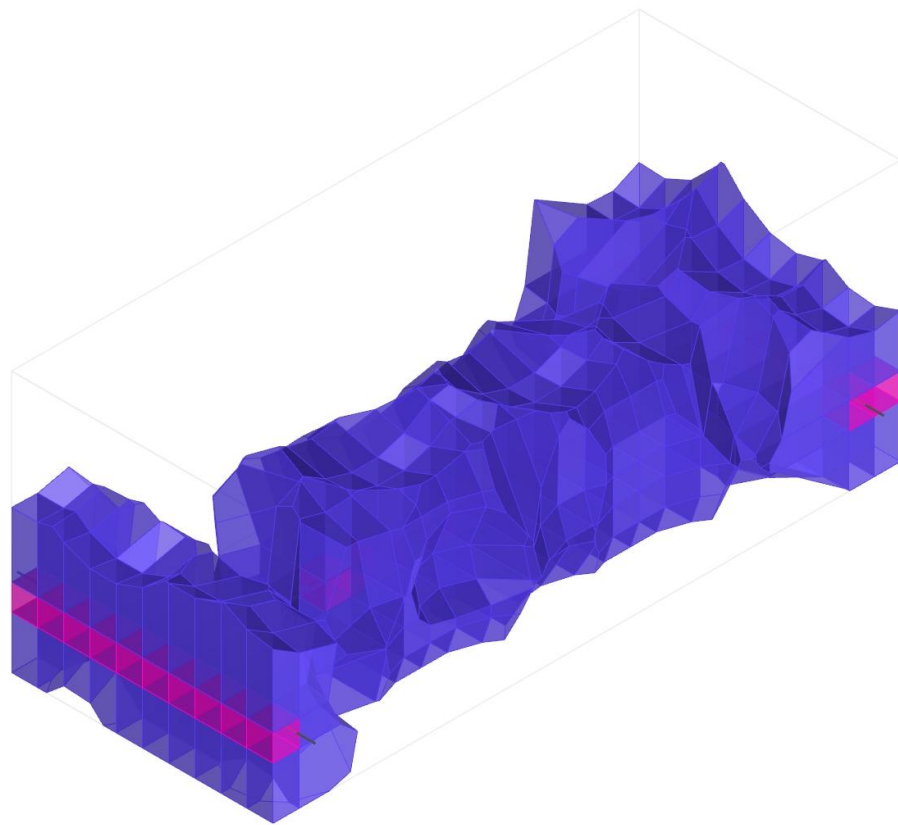

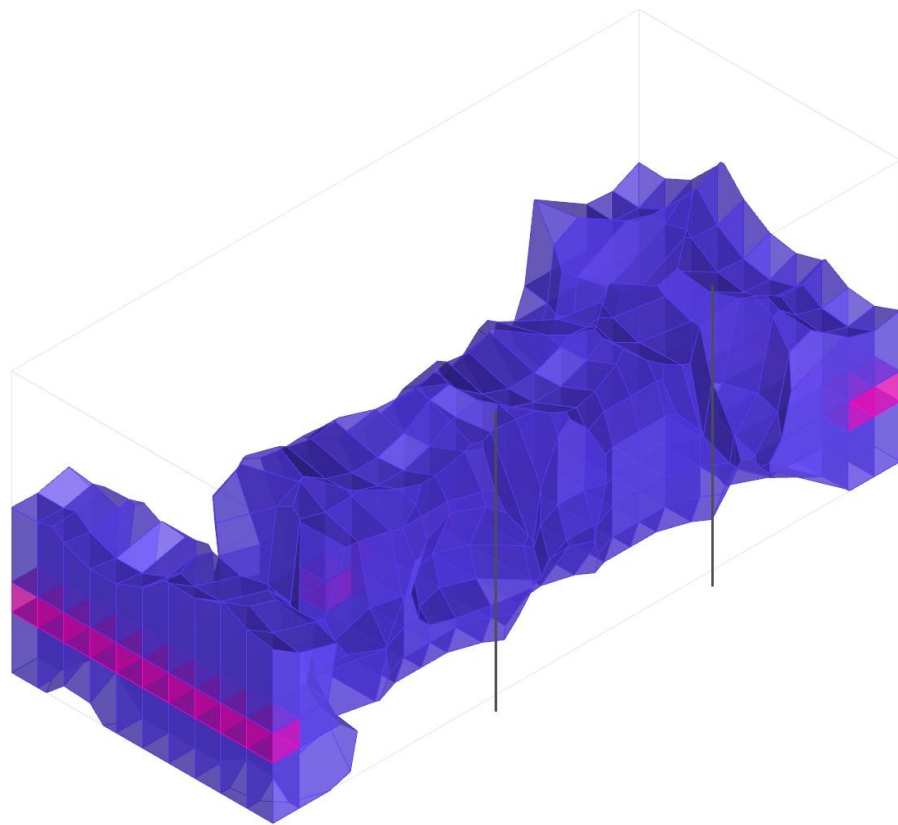

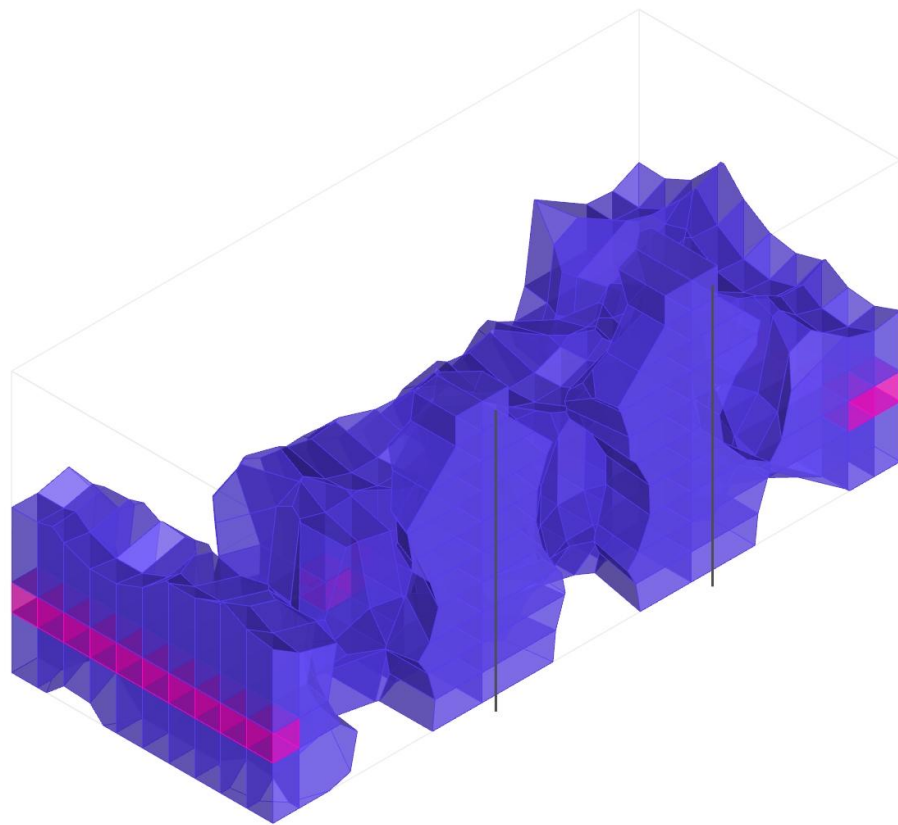

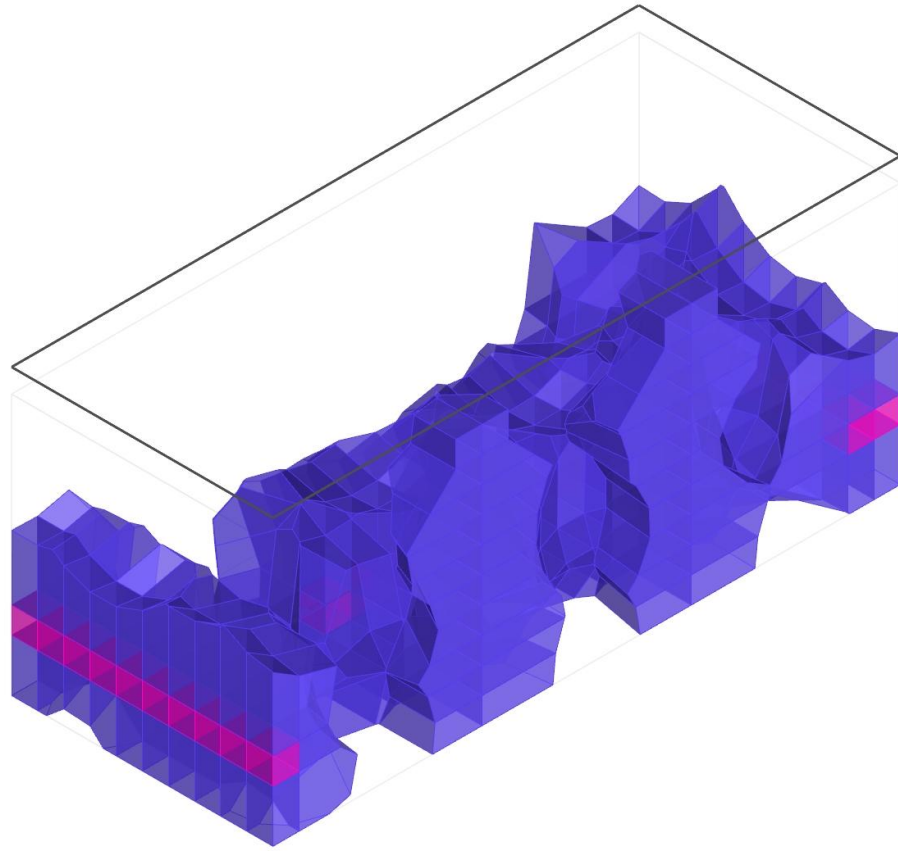

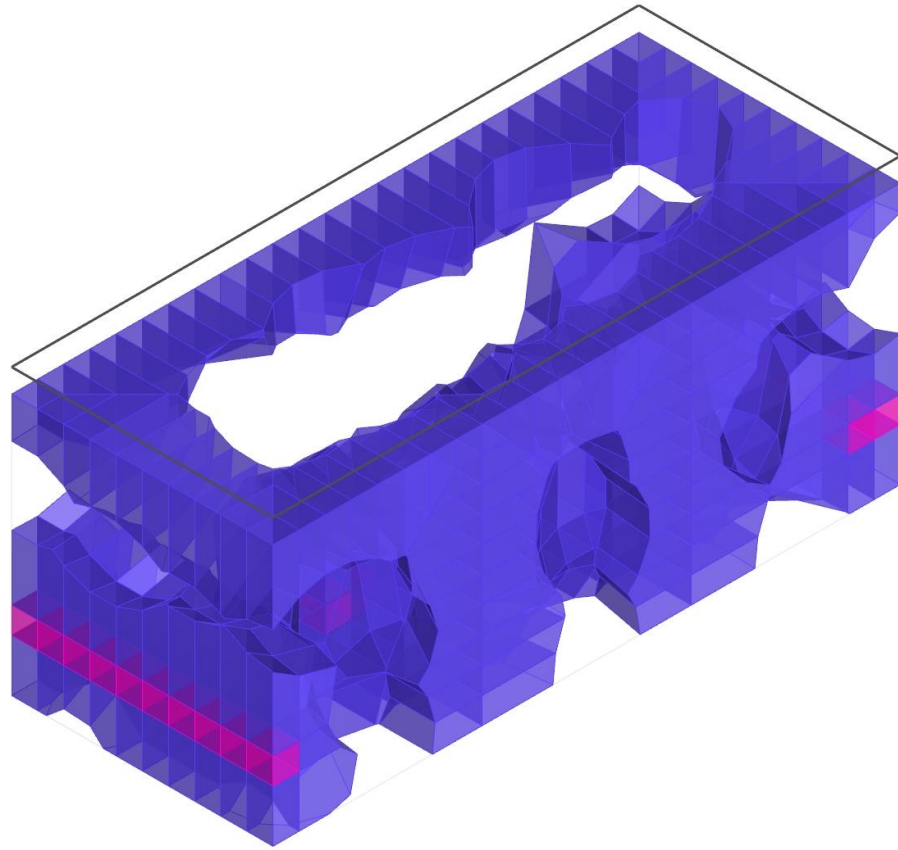

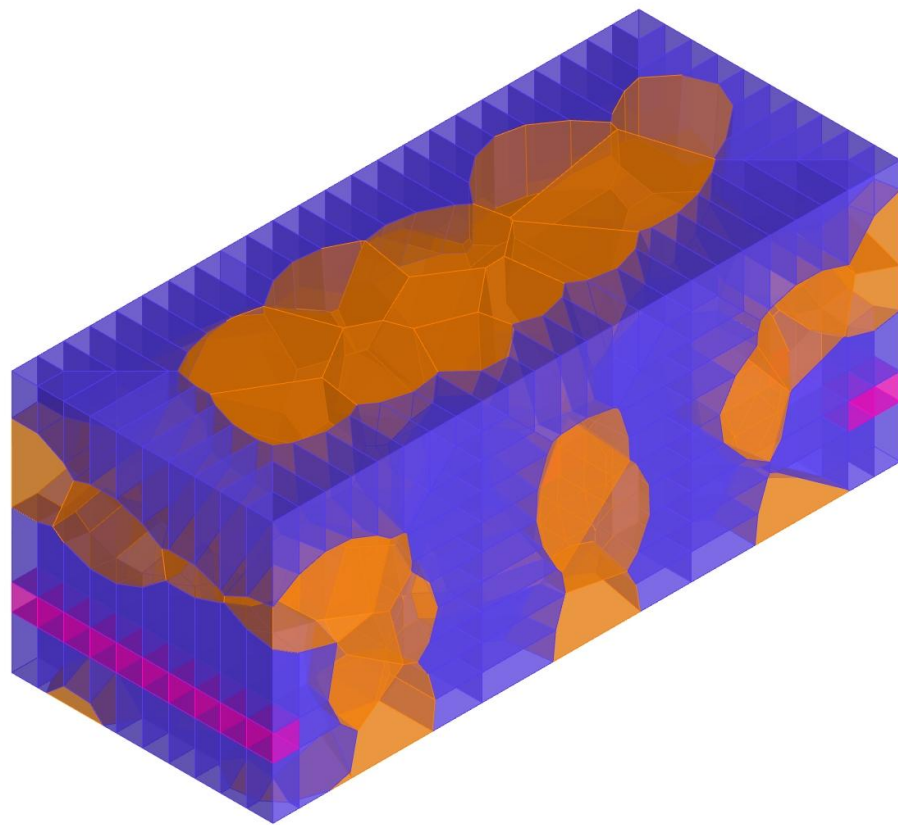

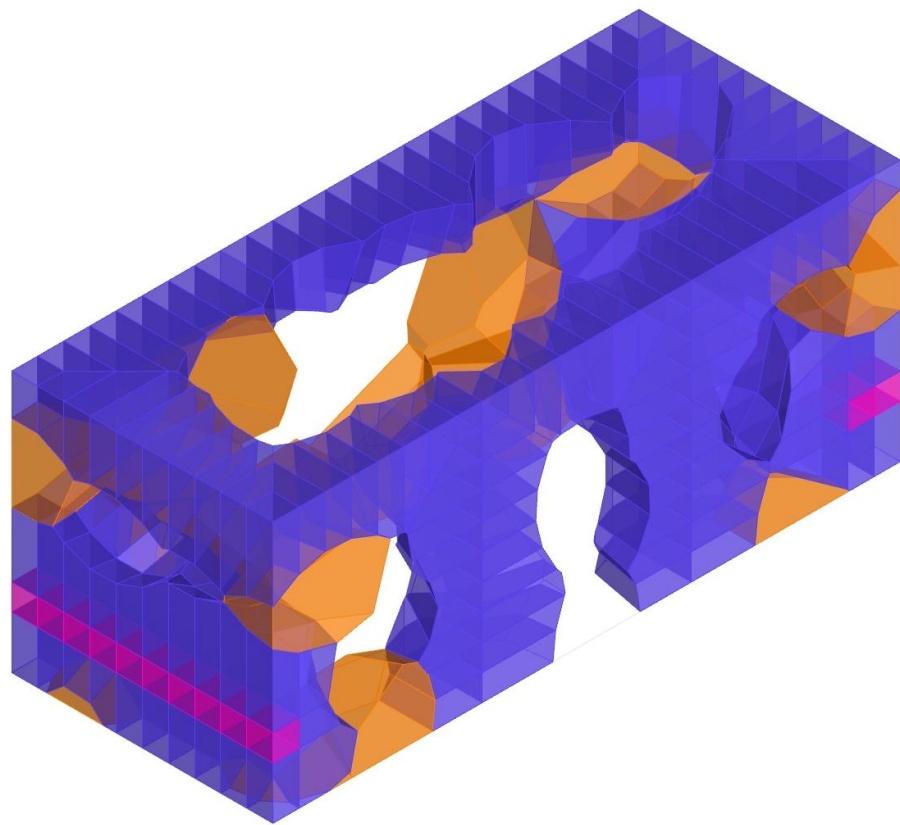

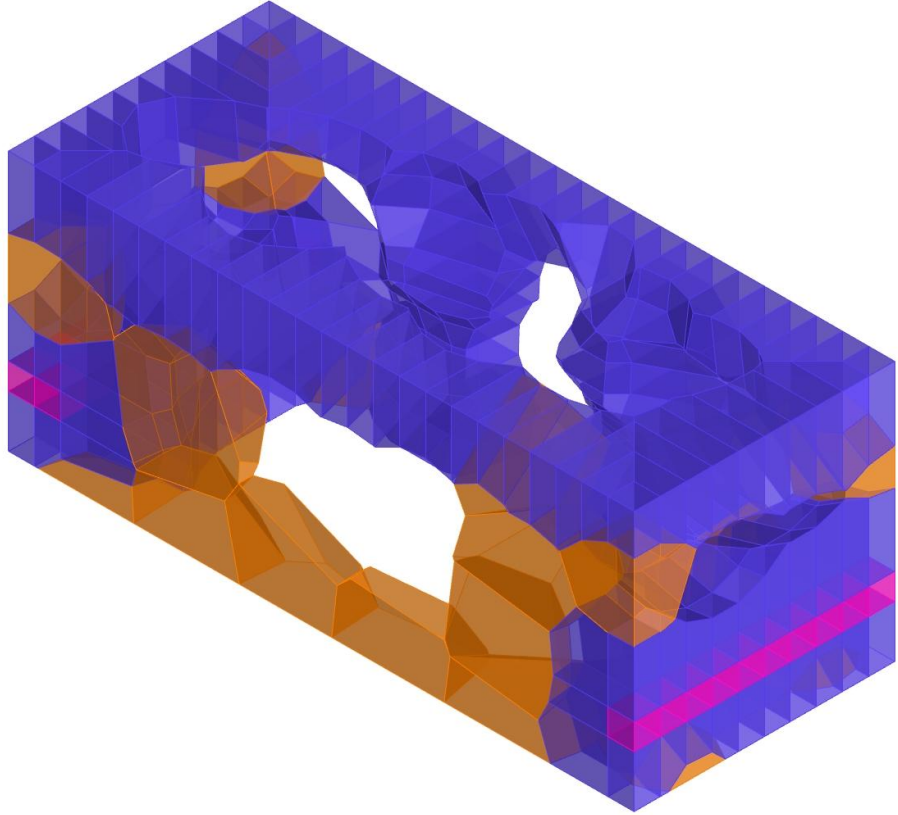

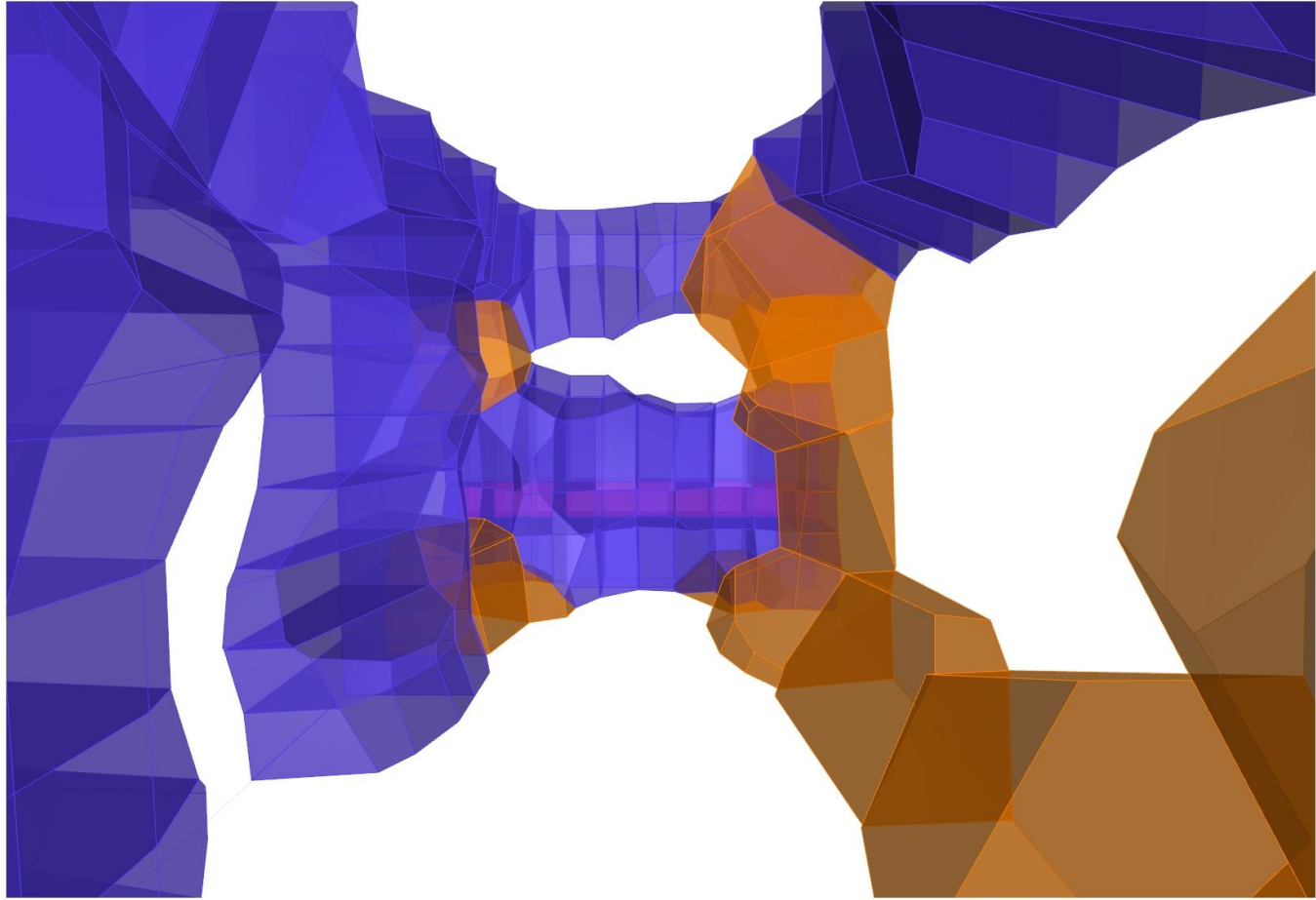



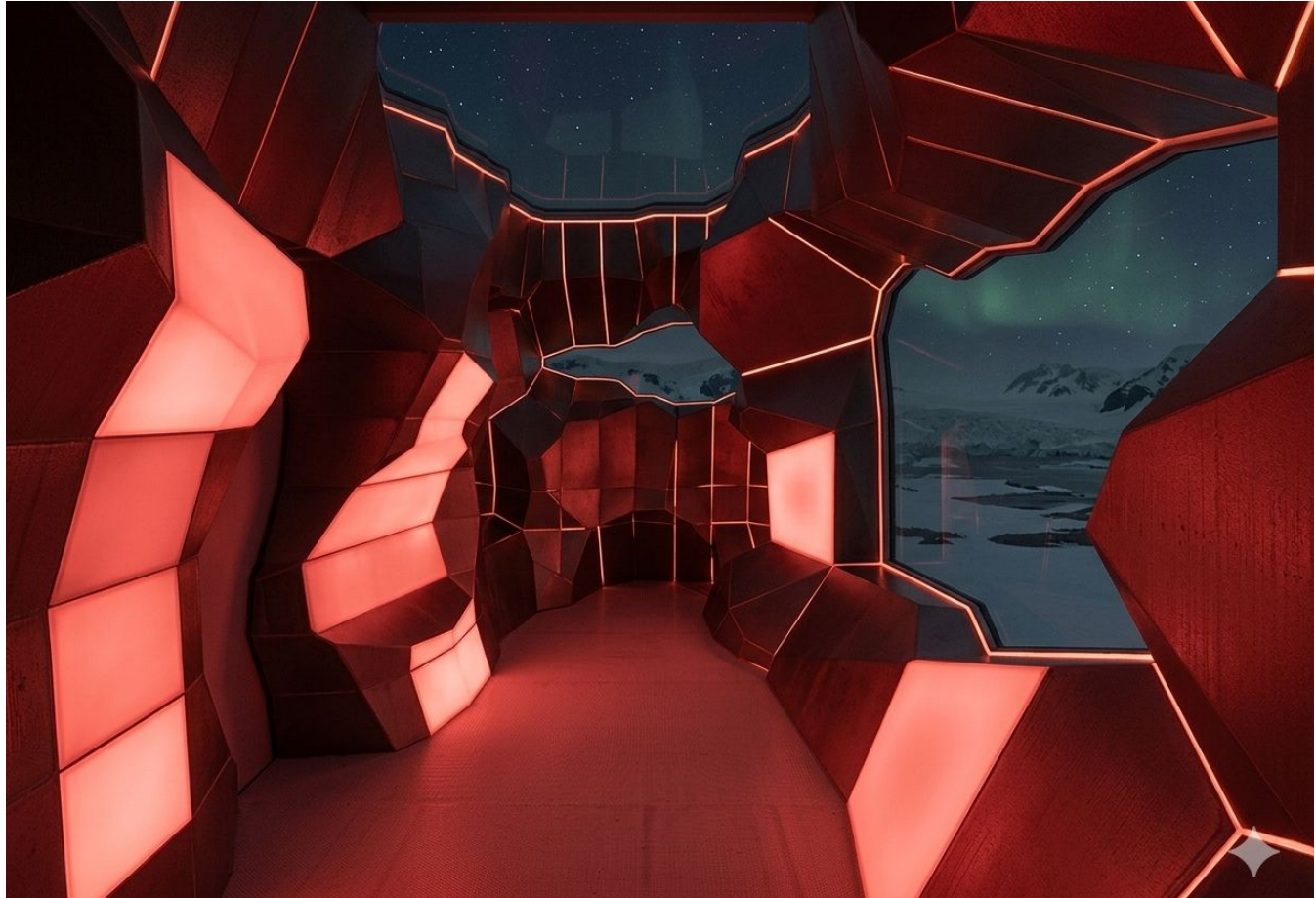

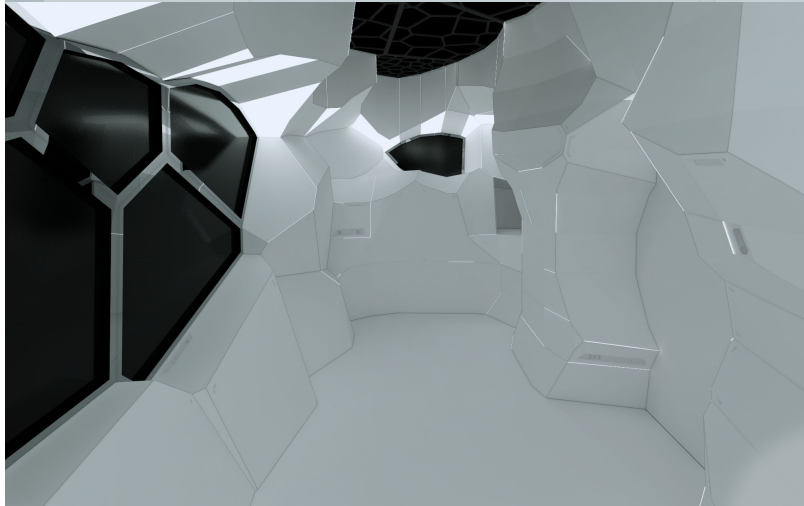
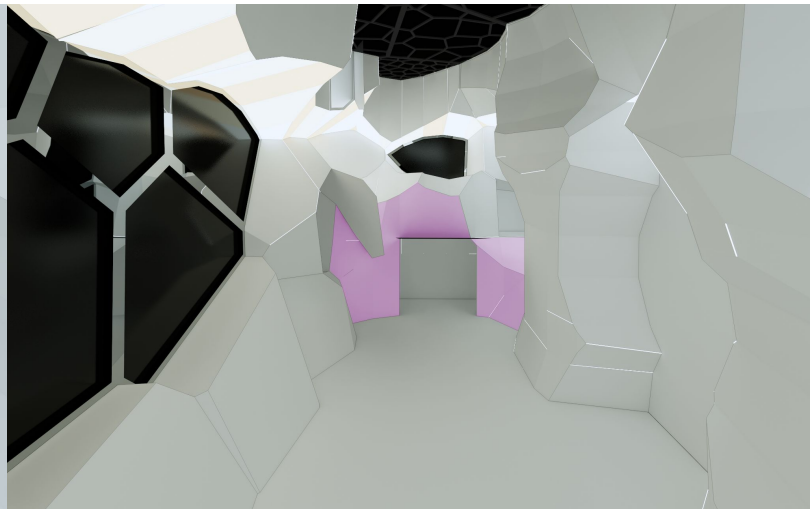
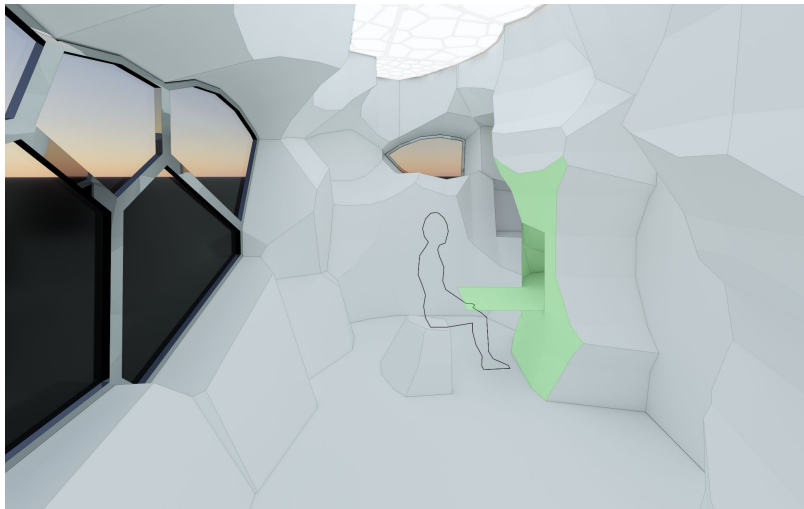

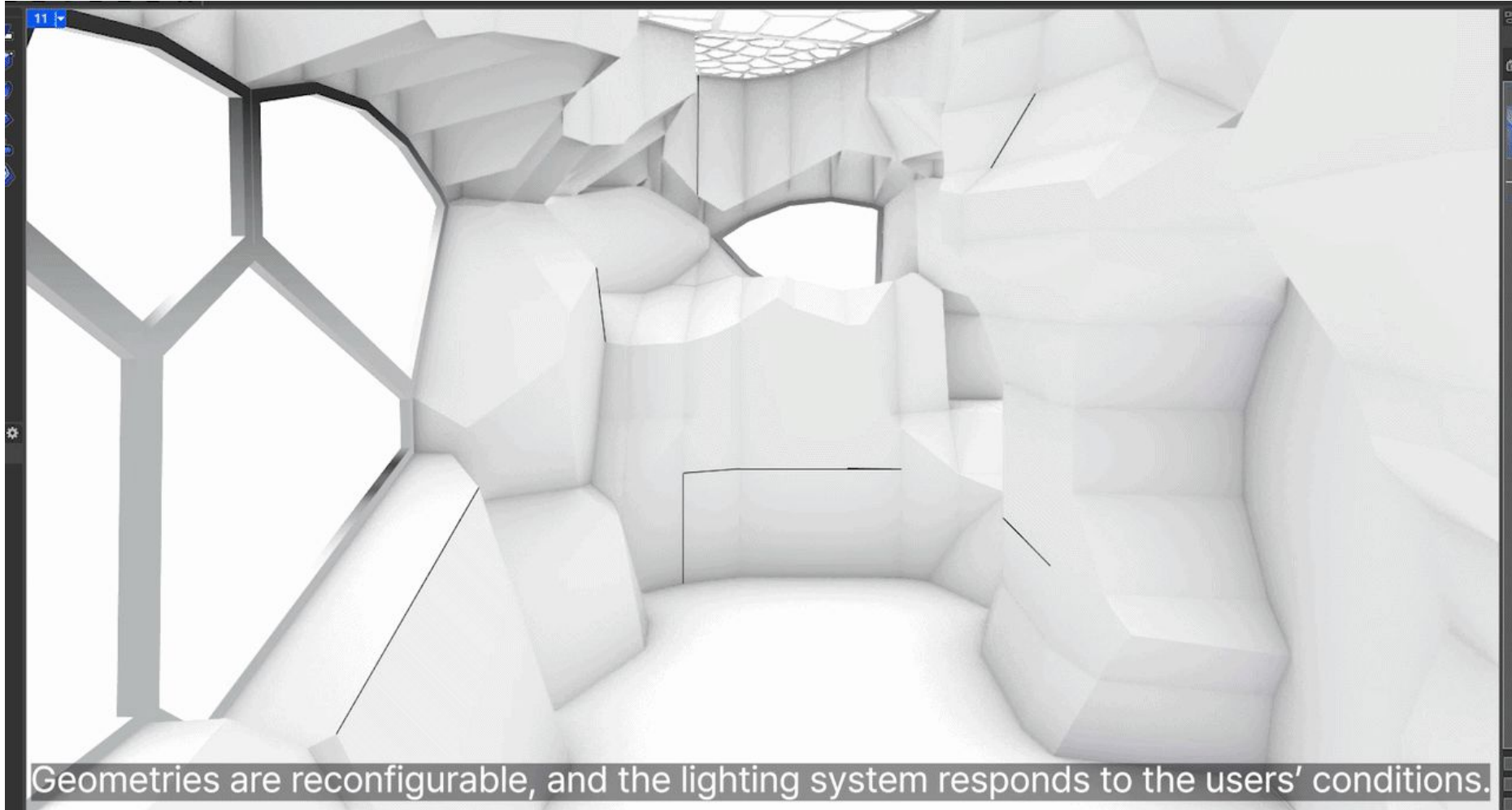

Geometries are reconfigurable, and the lighting system responds to the users' conditions.



IAP · MSC2 · TU DELFT · ANTARCTICA

TROLL STATION — AI LIGHTING

01 — WEATHER SIM

02 — ENERGY

03 — PHYSIOLOGY

DAYLIGHT PARAMETERS

DATE

2025/06/04

HOUR OF DAY

3

CORRELATED COLOUR TEMPERATURE

2200 K



NIGHT

0 LX

+5:00 +22:00

ILLUMINANCE

0 / 1200 LX MAX

DAYLIGHT SIMULATION



2200K · 0 LX

Thank you

:>]

Voronoi

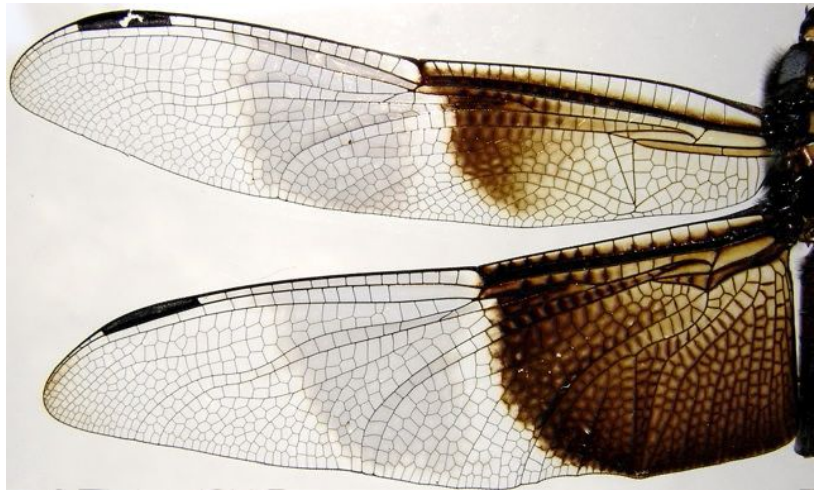

Form creation

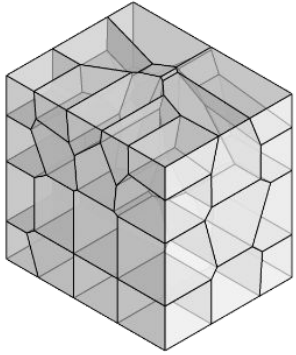

Body

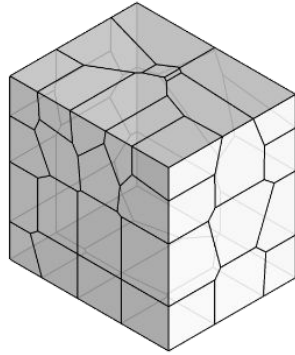

Skin

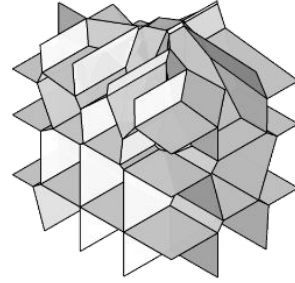

Bones

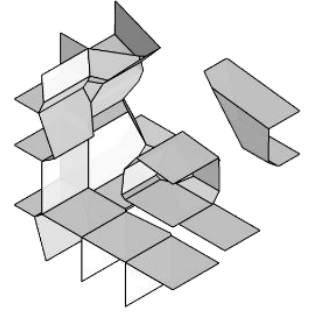

De-boning

Form creation

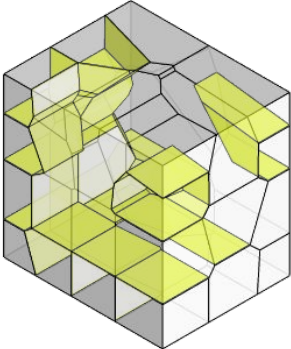

Coupling

Separation Closing

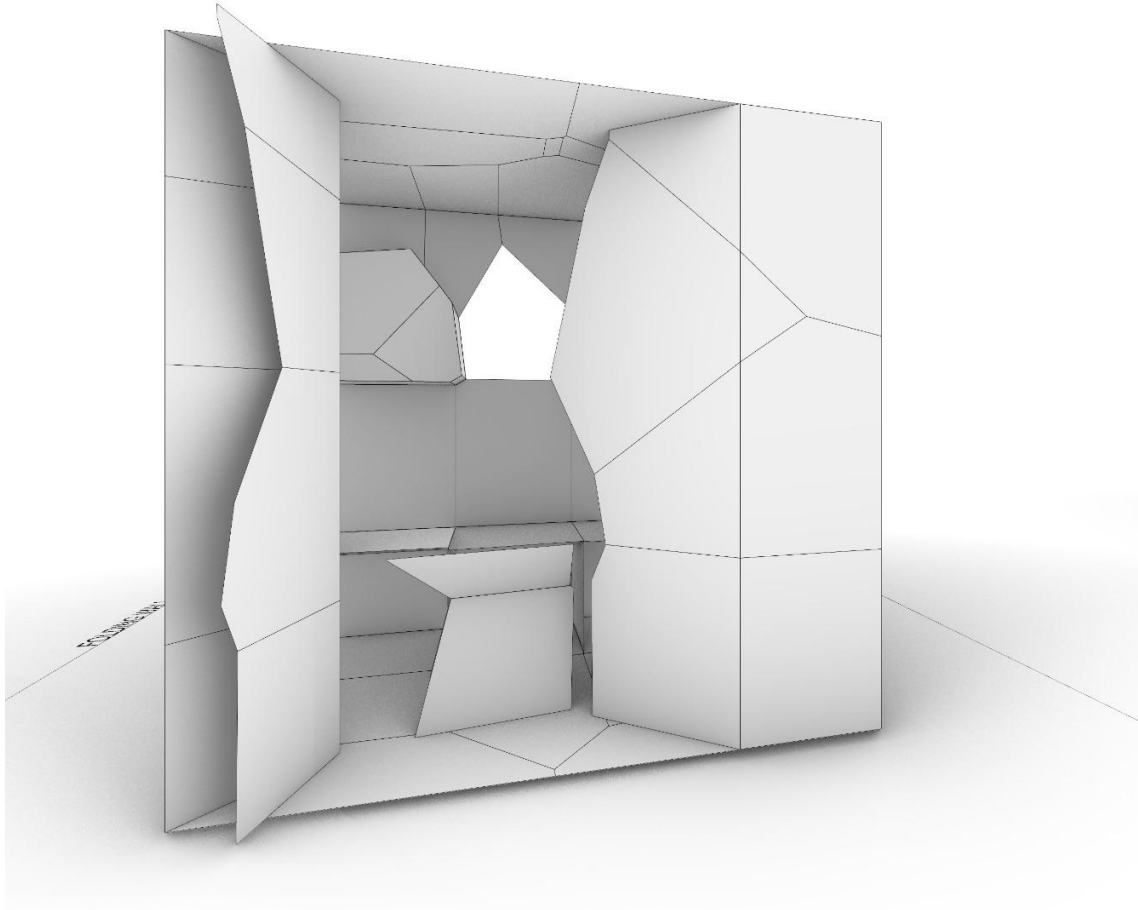

Separation Opening

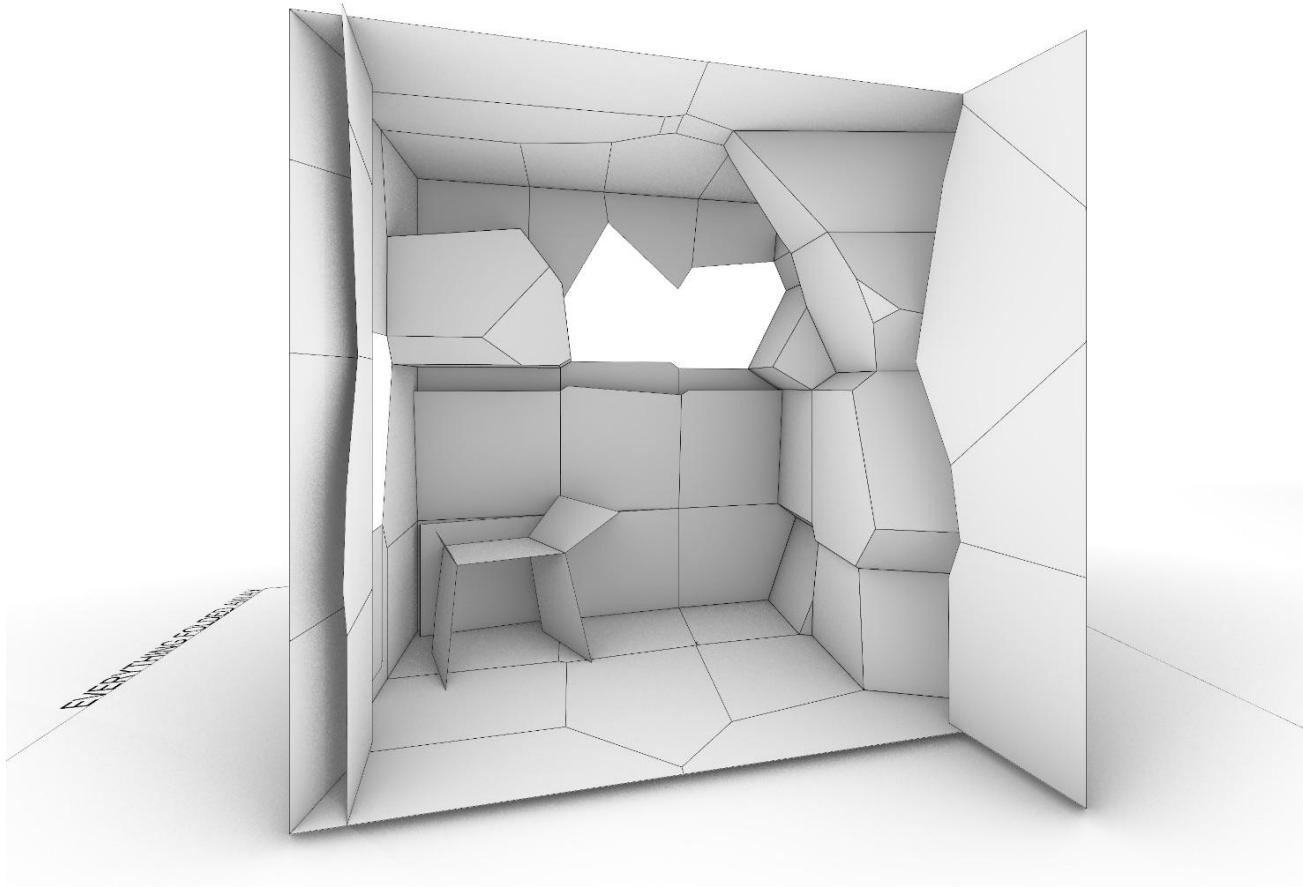

Unfolded

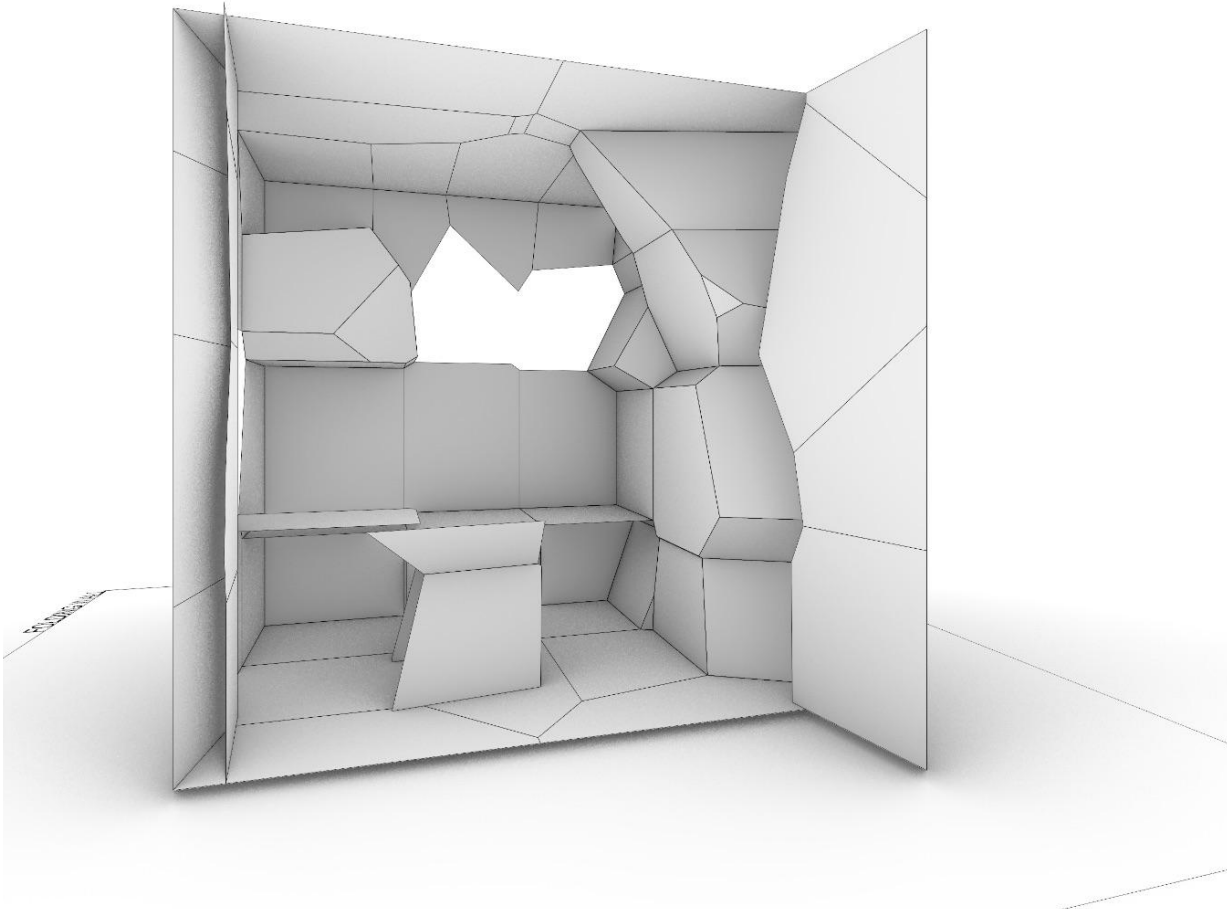

Folded

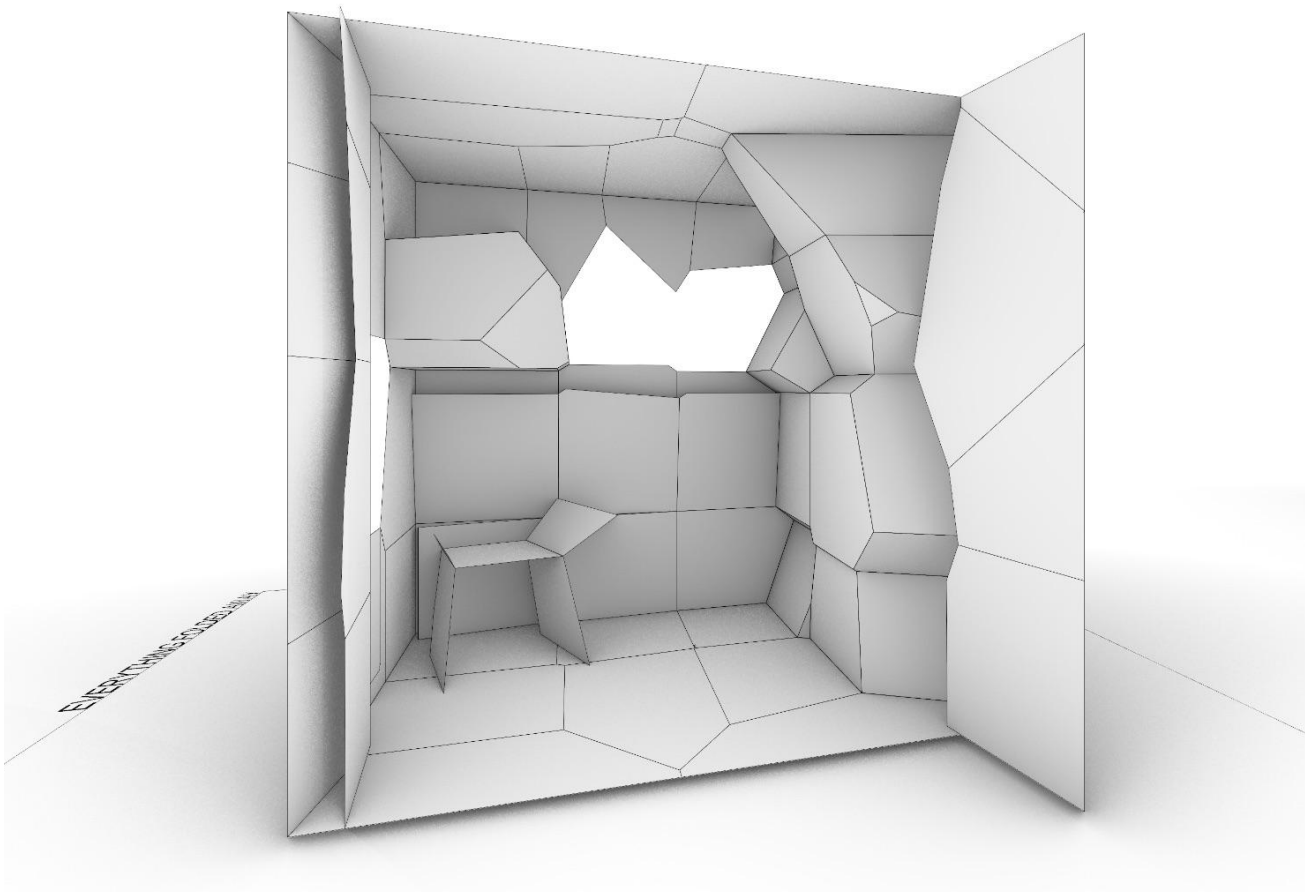

Storage

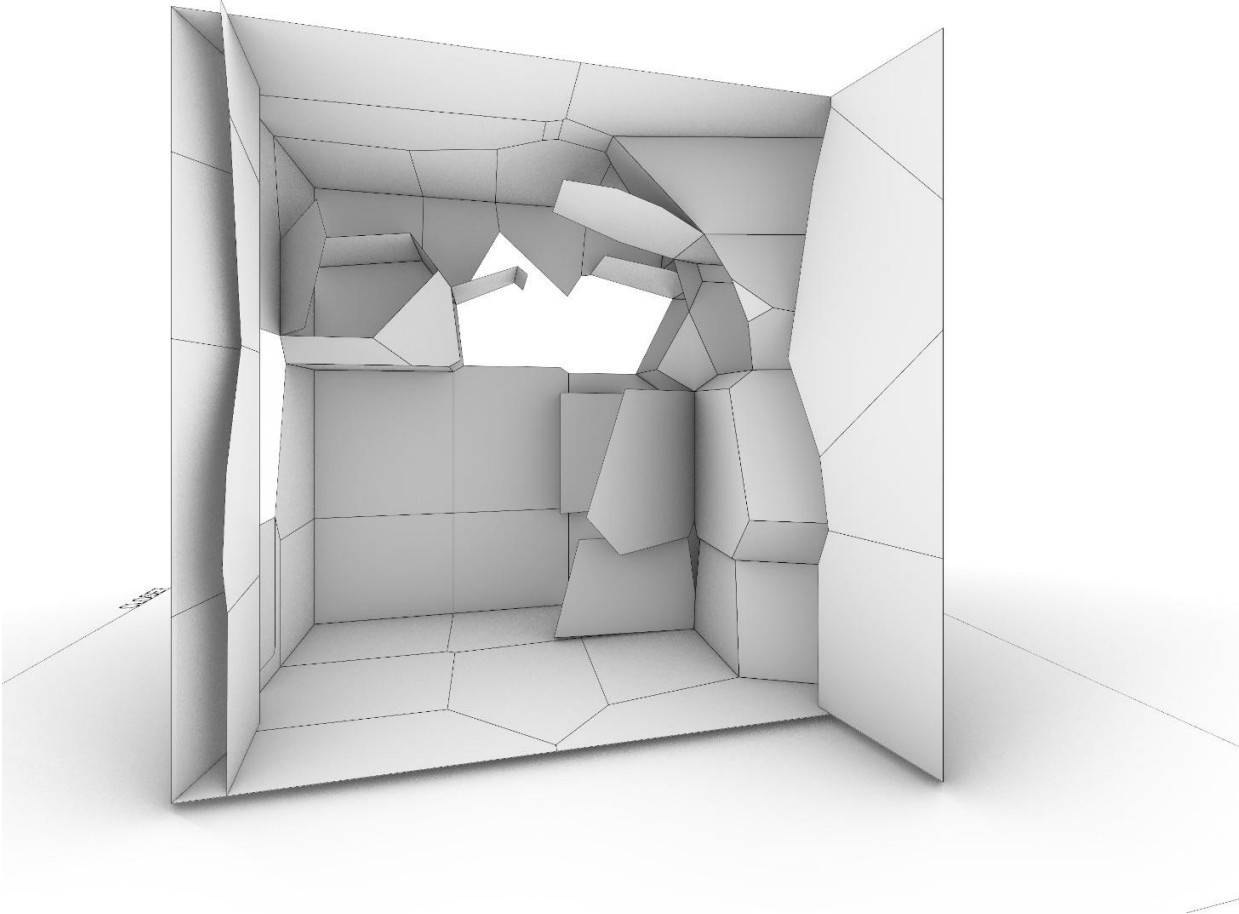

Lounging

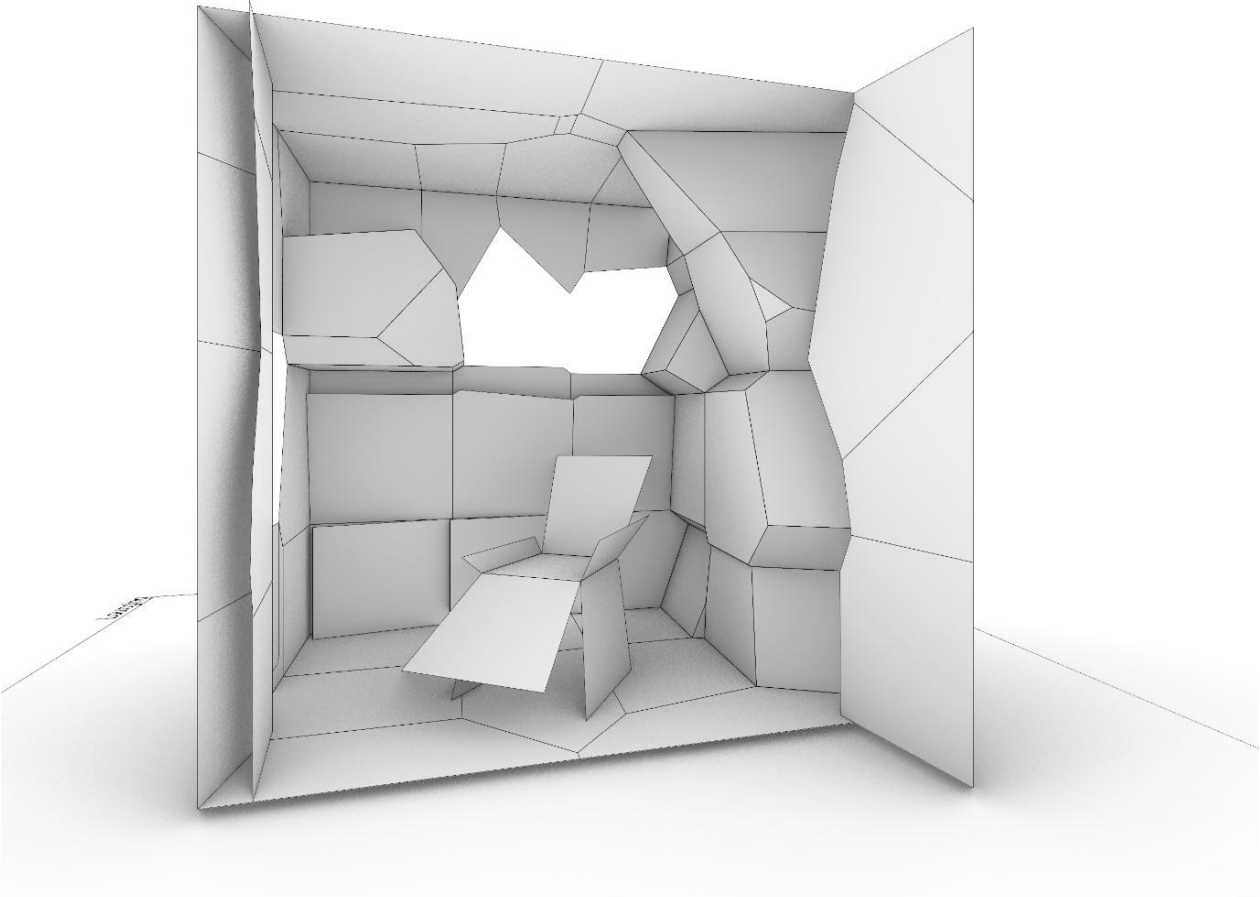

Working

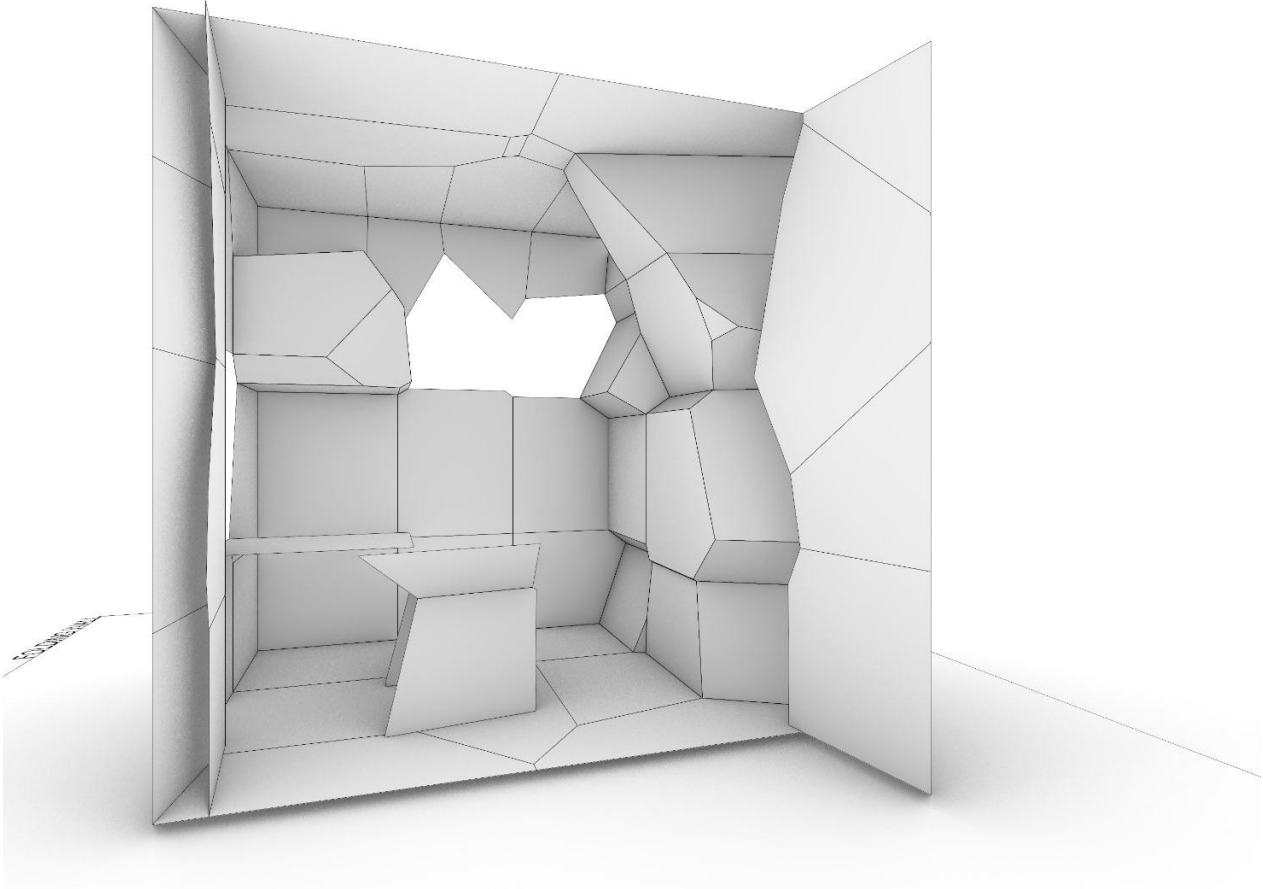

Sleeping

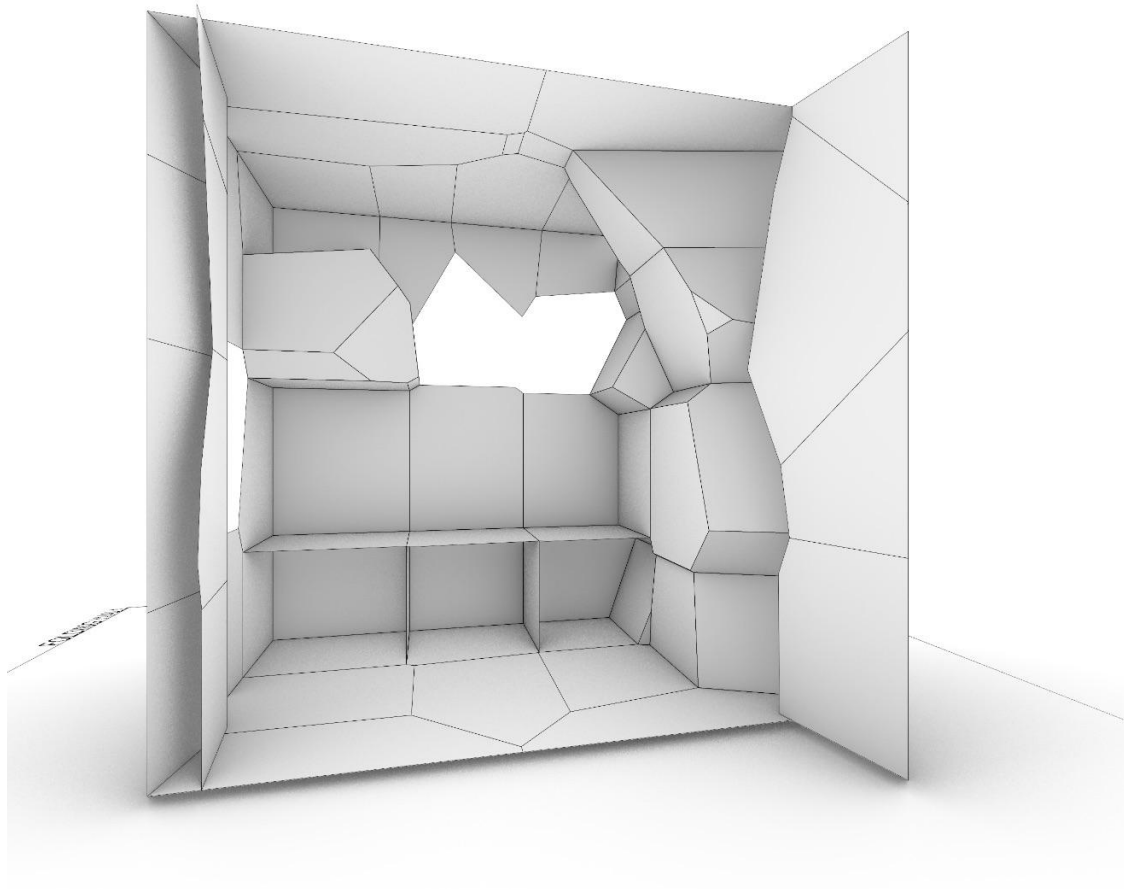

Nighttime

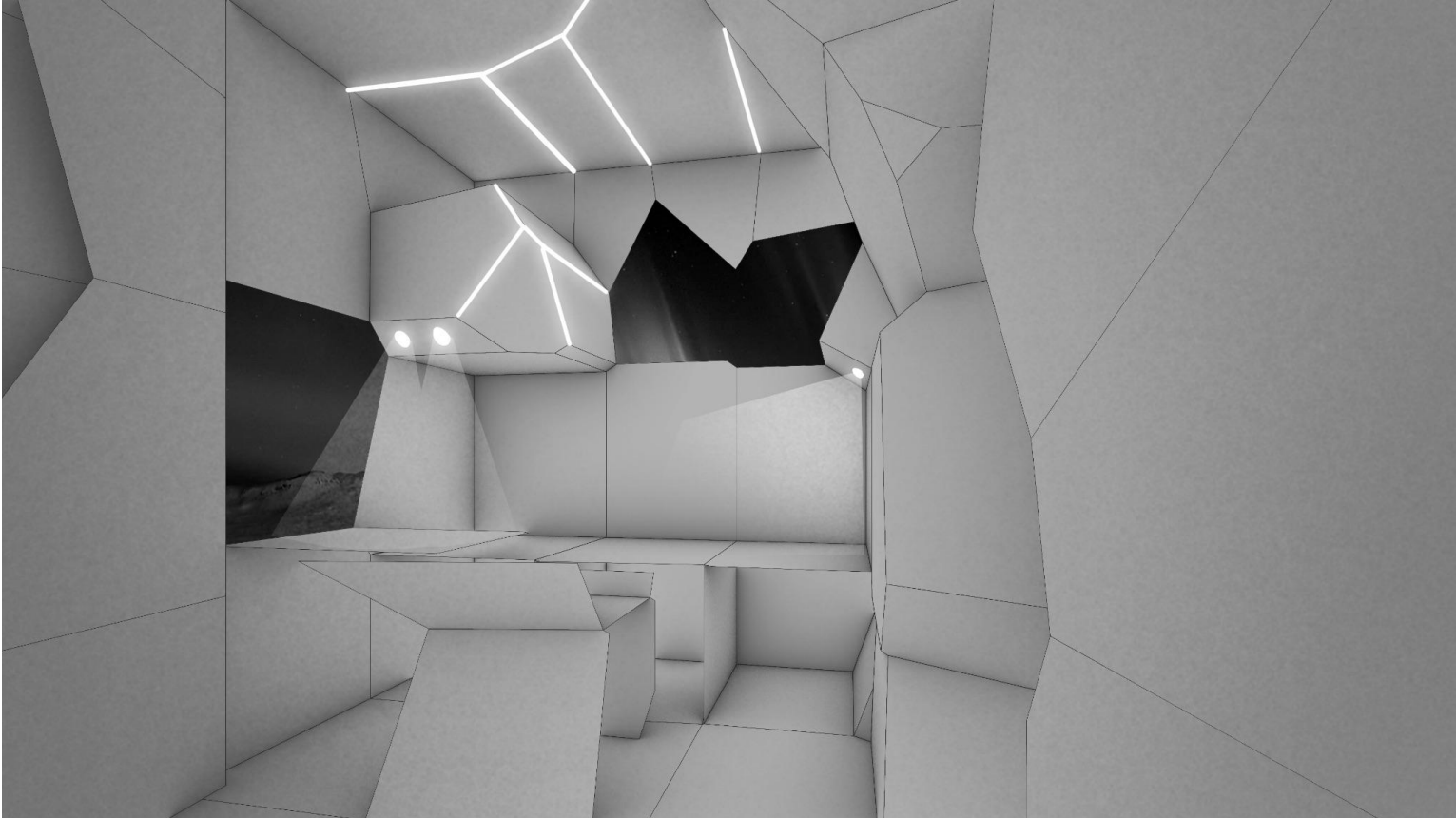

Nighttime

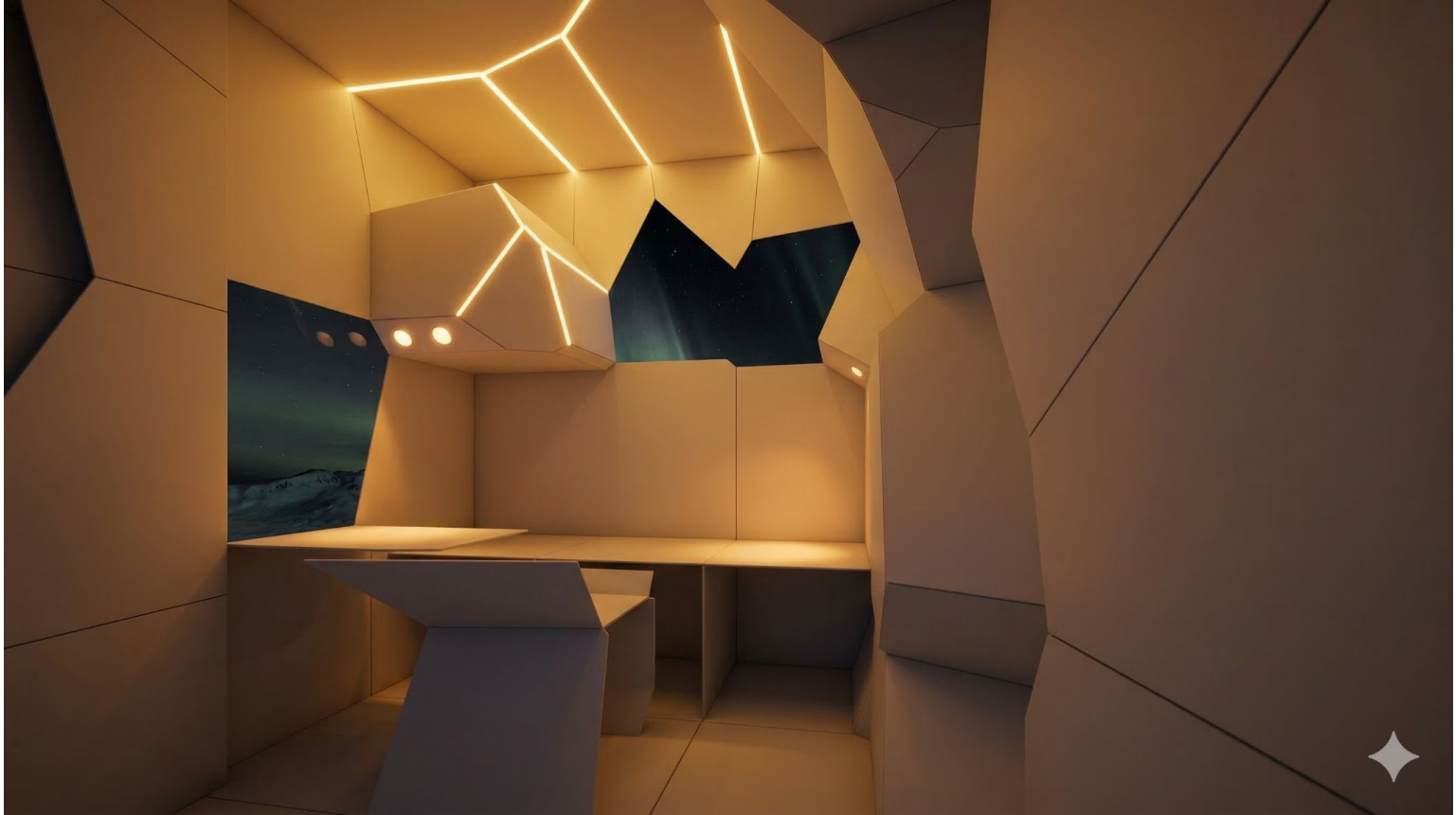

Daytime

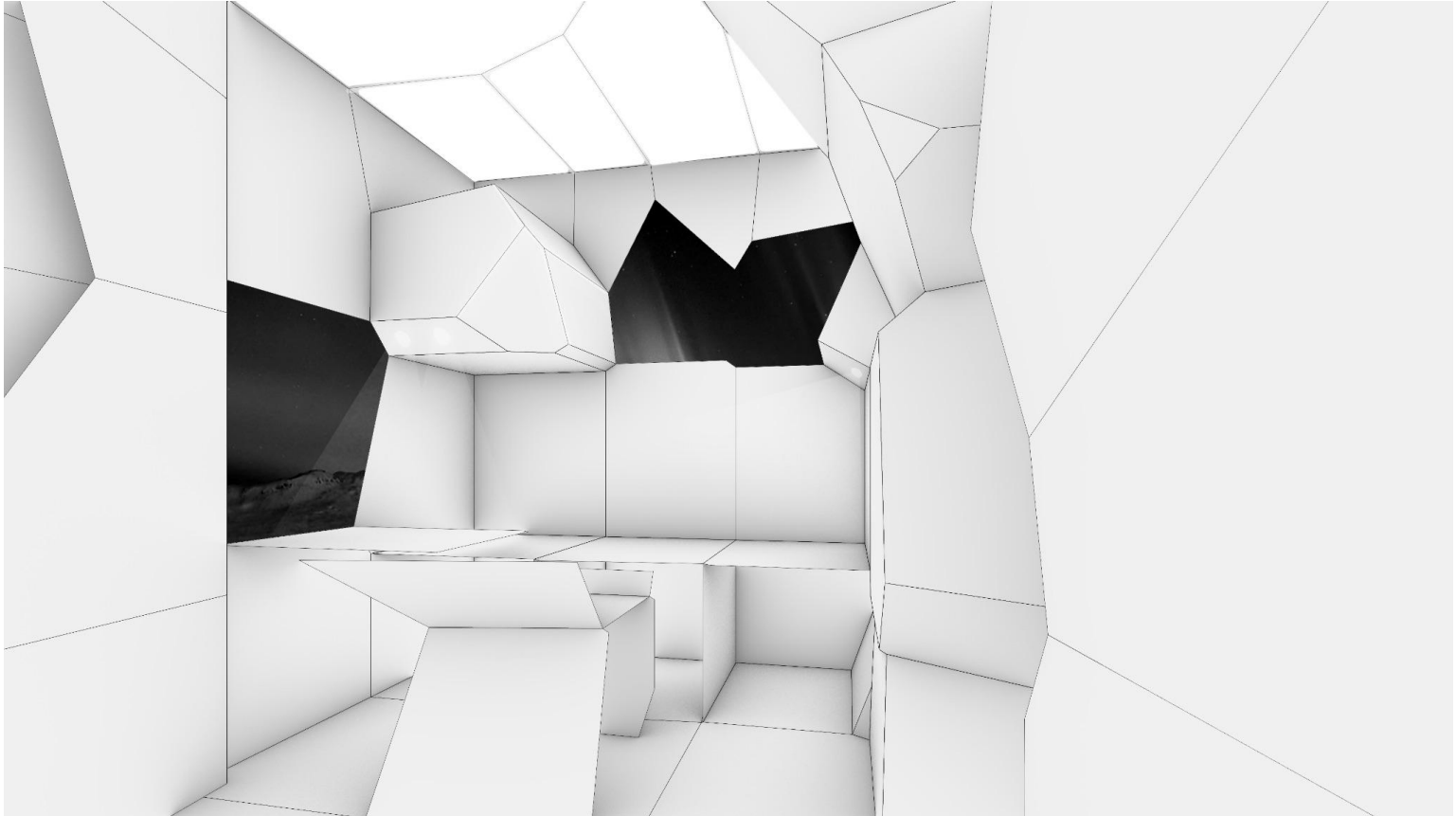

Choose coordinate system (CPlane World): _World
Choose world view (Top Bottom Left Right Front Back Perspective TwoPointPerspective): _Top
Command:

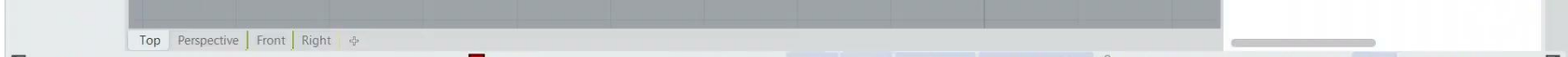
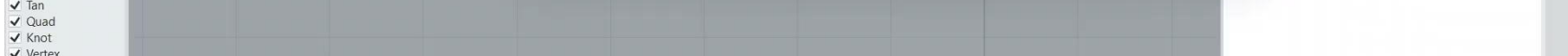
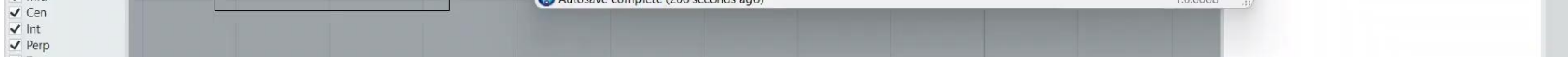

Choose world view (Top Bottom Left Right Front Back Perspective TwoPointPerspective):_Top
Command: Grasshopper

Command:



Screen Recorder
Full Screen
00:00:00 | Initiating

Grasshopper - testing*
File Edit View Display Solution Help Karamba3D ShapeDiver testing*
Primitive Input Rhino Util
Autosave complete (120 seconds ago) 1.0.0008

- Osnap
- End
 - Near
 - Point
 - Mid
 - Cen
 - Int
 - Perp
 - Tan
 - Quad
 - Knot
 - Vertex
 - Project
 - Disable

| | Curr | Material |
|----------|-------------------------------------|----------|
| Default | | |
| Layer 01 | <input checked="" type="checkbox"/> | |
| Layer 02 | | |
| Layer 03 | | |
| Layer 04 | | |
| Layer 05 | | |

Display mode set to "Pen".
Tap Alt to make a duplicate
Command:

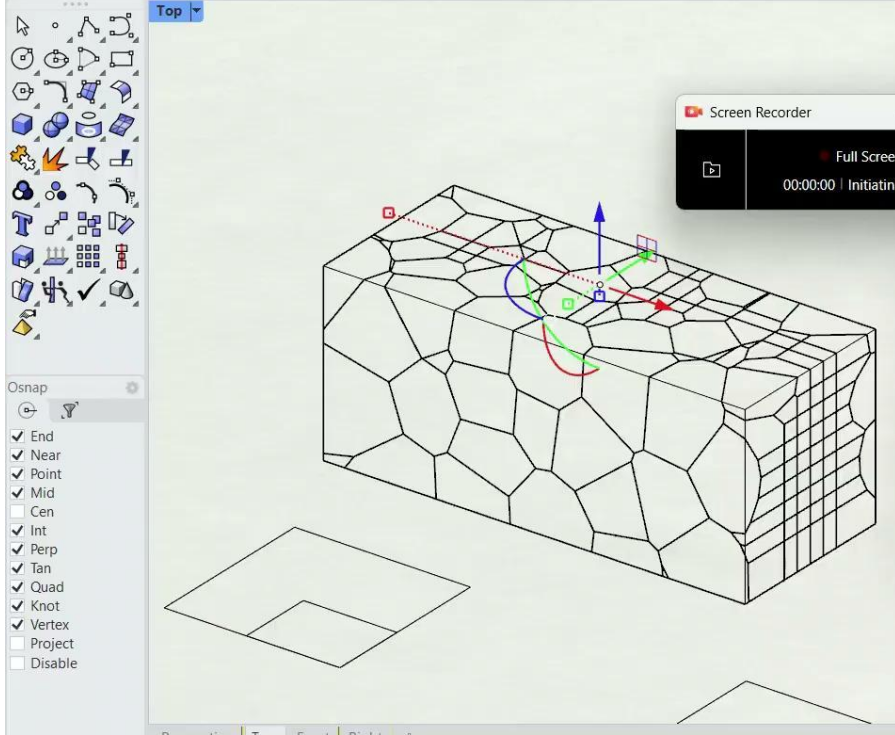

- Osnap
- End
 - Near
 - Point
 - Mid
 - Cen
 - Int
 - Perp
 - Tan
 - Quad
 - Knot
 - Vertex
 - Project
 - Disable

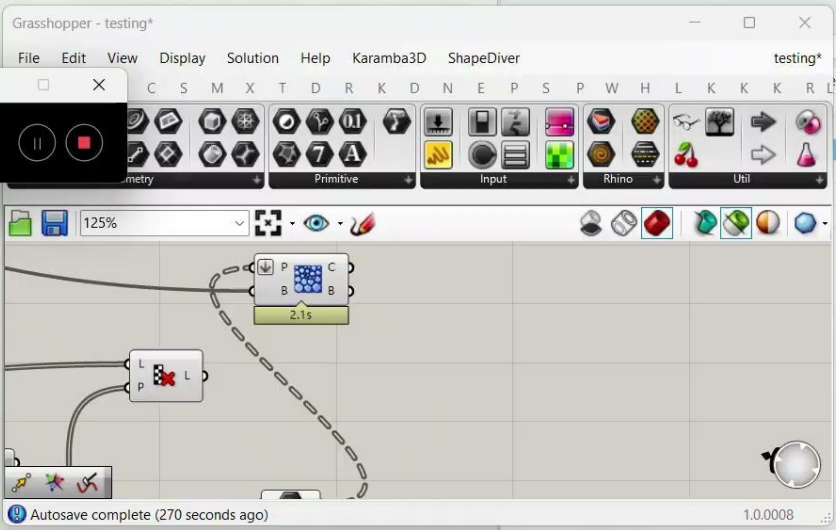
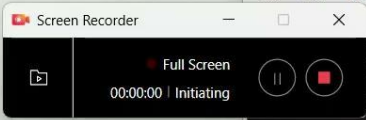

Tap Alt to make a duplicate
Command: Grasshopper

Command:

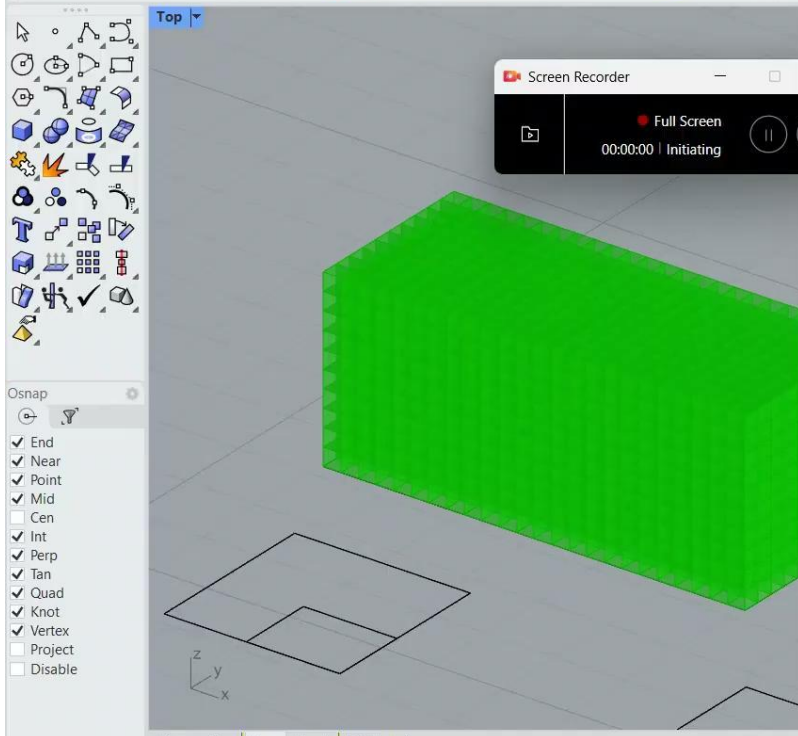

- Osnap
- End
 - Near
 - Point
 - Mid
 - Cen
 - Int
 - Perp
 - Tan
 - Quad
 - Knot
 - Vertex
 - Project
 - Disable

Screen Recorder

Full Screen

00:00:00 | Initiating

My Videos - Screen Recorder

| | | | | | |
|--|---|--|--|--|--|
| | 20260316110412.mp4 16/03/2026 11:04:12 | | | | |
| | 20260316110311.mp4 16/03/2026 11:03:11 | | | | |
| | 20260312182614.mp4 12/03/2026 18:26:14 | | | | |
| | 20260312182117.mp4 12/03/2026 18:21:17 | | | | |
| | 20260312182008.mp4 12/03/2026 18:20:08 | | | | |
| | 20260227080419.mp4 27/02/2026 08:04:19 | | | | |

testing*

K K K R trial

Util

1.0.0008

05
Material



A Text

- .
- .
- .
- .

B Text

C Text

- .
- .
- .
- .

05 Material From waste to use

Reference: KLM - From recycled plastic bottles to 3D printed aircraft tools for maintenance

<https://www.voxelmatters.com/klm-3d-printing-tools-plastic-bottles/>

Collect leftover PET bottles



Plastic Pellet

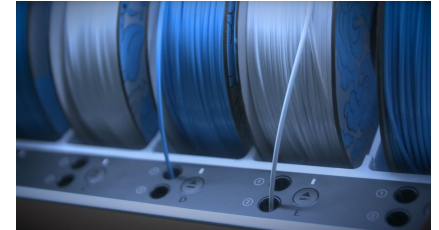
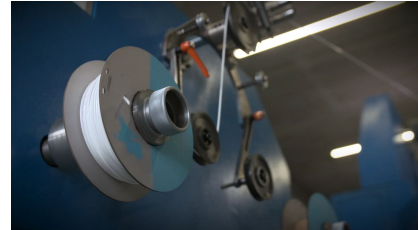
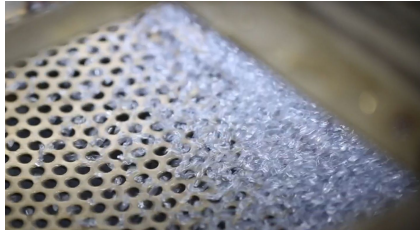

PLA Filament

05 Material Reference

Reference: Van Plastik – From recycled plastic waste to 3D printed furniture.

<https://vanplastik.nl/en/about-vanplastik/>

Semi-transparent

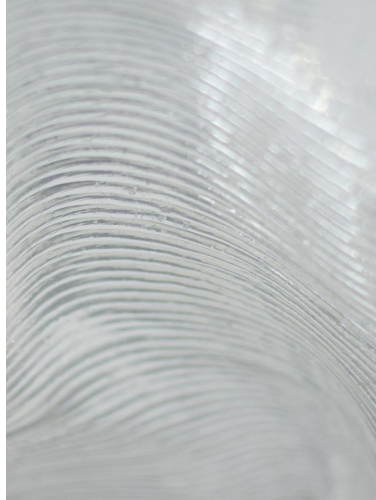

White Matte

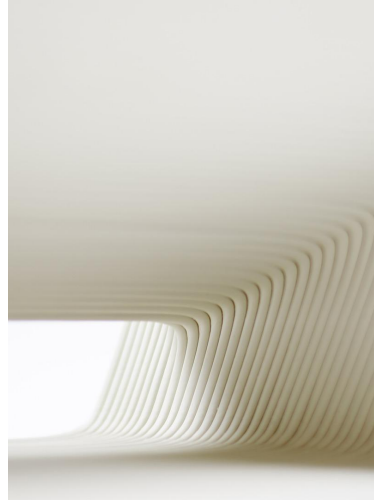

05 Material on-site vs outside fabrication

ON-SITE PRODUCTION

- Additive manufacturing (large-scale 3D printing) enables the direct fabrication of the Voronoi structure on site
- Use local recycled materials (bioplastics, reinforced polymers)
- Requires temporary infrastructure: energy supply, protected workspace, robotic equipment
- Allows real-time adaptation to site conditions and design adjustments
- Reduces transportation impact and logistics complexity
- **Limitations:** longer production time, technical expertise required, machine constraints

OUTSIDE PRODUCTION

- Prefabrication in controlled environments ensures high precision and quality
- Components are modular, lightweight, and optimized for transport (container-based logistics)
- Pre-integration of systems: LED strips, wiring, connection nodes
- Enables fast on-site assembly through plug-in connections
- **Limitations:** higher transport costs, limited adaptability, dependency on supply chains

HYBRID PRODUCTION

- Combine prefabricated structural modules with on-site customization
 - Balance between industrial efficiency and local adaptability
 - Enhances both design flexibility and logistical feasibility

05 Material Assembly

By Box

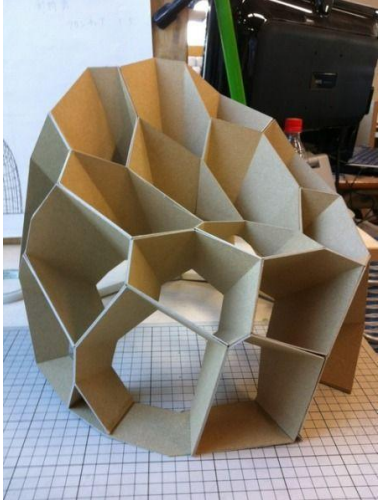

By Panel - Edges

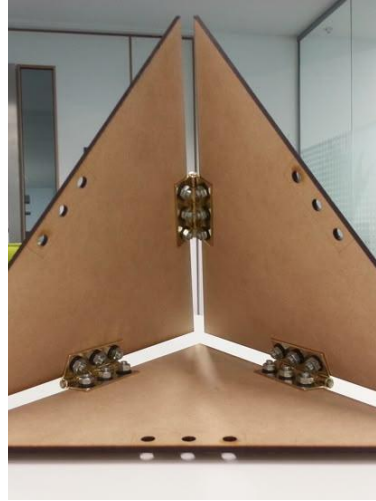
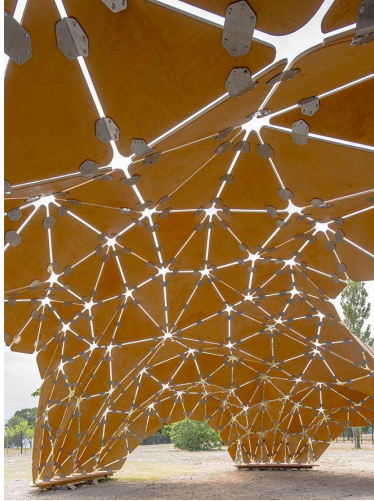

By Panel - Vertex

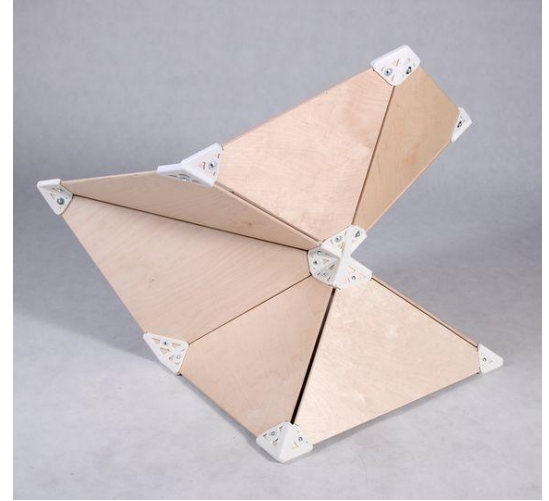

05 Material Visualization



Lighting and AI Integration **Lighting types**

(I) Skylight

- + Human Activity Recognition (HAR)
- + Reacting to a daylight cycle
- + Performative Uses (i.e. Wind blowing through leaves)

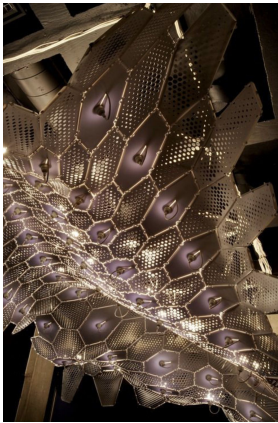

(II) Light as Spectacle

- + Computer Vision (CV) translates outdoor environment into spectacle
- + Performative
- + Cognitive Stimulation and Psychological orientation
- + Shows live from outside

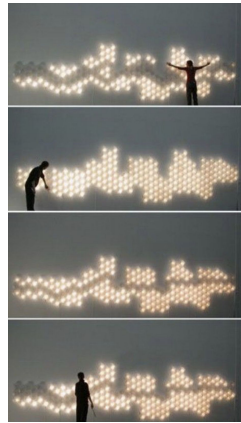

(III) Individual Lighting

- + Autoregressive (AR)
- + Personalized circadian cycle
- + Personalized atmospheric lighting
- + Reaction to physiological factors eg. heart rate

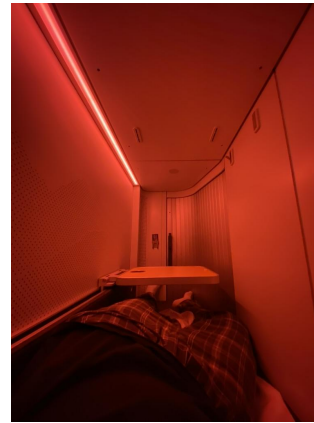

(IV) Light Therapy

- + Red-light (630–850nm) for recovery + mood
- + 10,000 lux daylight therapy for winter activation

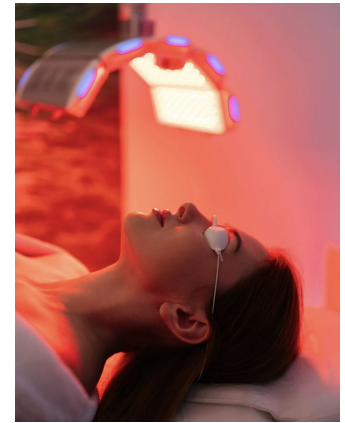

Lighting and AI Integration **Goals for AI integration**

01: Circadian Rhythm Preservation

- + Simulates a full Delft daylight cycle inside the container
- + Any date selectable — captures seasonal variation across the year
- + Maintains sleep, melatonin and mood cycles during polar night

02: Environmental Energy Optimisation

- + Outdoor conditions drive indoor light levels automatically
- + Bright sun outside —> dims indoor lights
- + Heavy cloud / polar darkness —> boosts indoor light
- + Minimises energy use

03: Personalised Physiological Response

- + Neural network predicts ideal light from body signals
- + High stress detected —> warm dim light to lower heart rate
- + Balanced state —> model prediction applied directly
- + Lighting actively responds to each researcher's biological state

04: Ability to choose own lighting

- + Overrides system lighting for user needs (Have 4 simulation modes for users to choose from - or full RGB range)

(I) Skylight

(II) Light as Spectacle

(I) Skylight

(III) Individual Lighting

(IV) Light Therapy

(I) Skylight

(III) Individual Lighting



99 Lighting and AI Integration

Step 1: Visualization of model

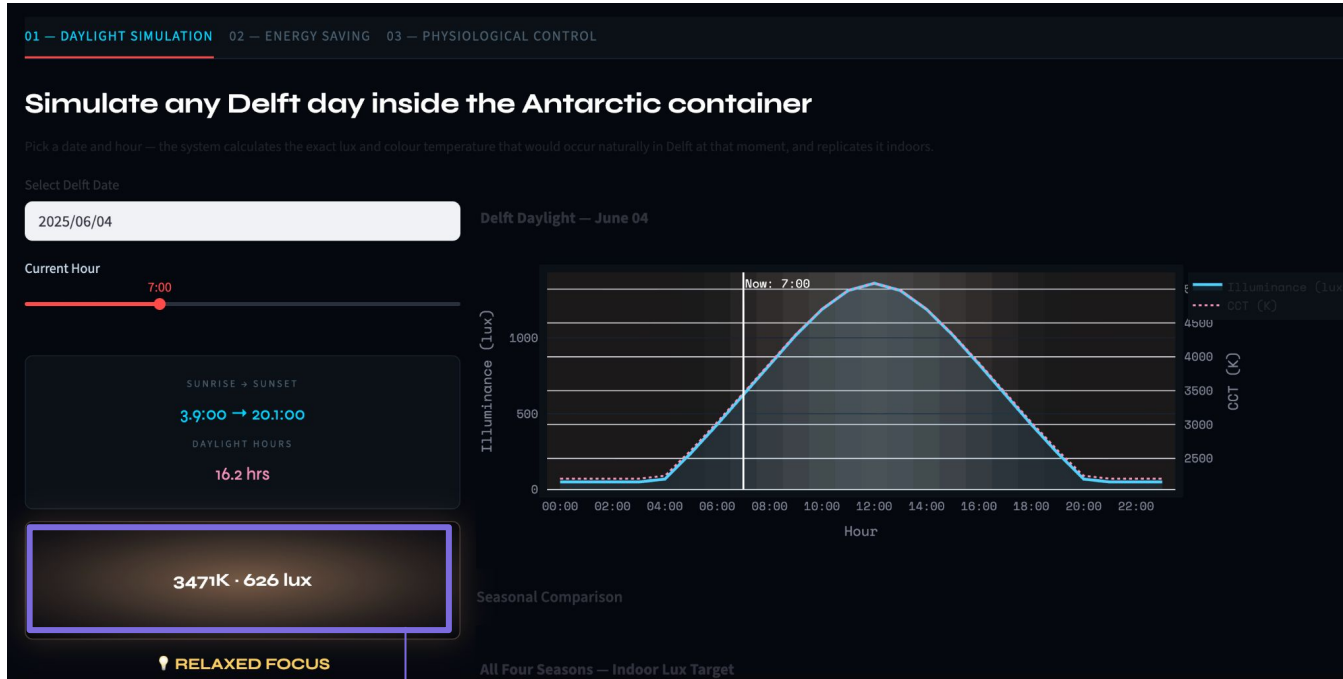

How can these results be realized practically in the container?
1. Color temperature 2. Lux(the unit of illuminance)

99 Lighting and AI Integration

Video showing visualization of output

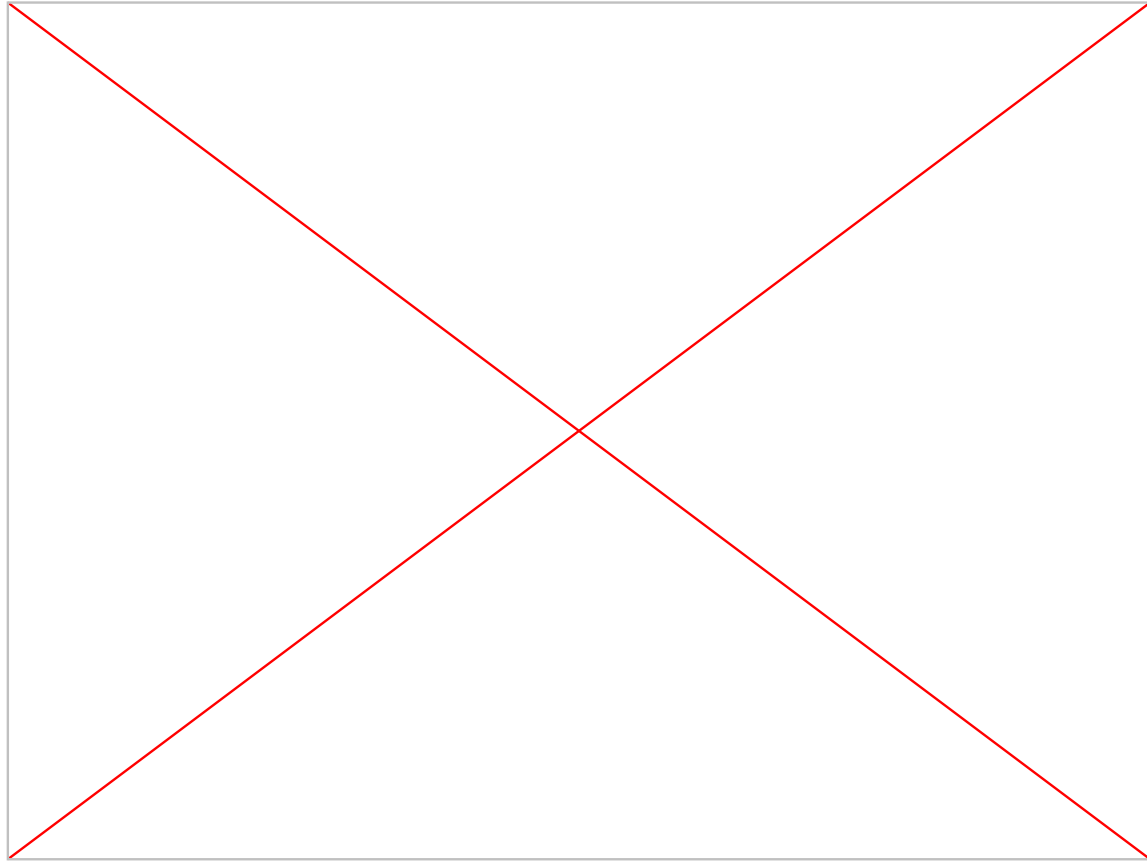

99 Lighting and AI Integration

Step 2: Light configuration

How can these results be realized practically in the container?

1. Color temperature **2. Lux (the unit of illuminance)**

3471K · 626 lux



Each cell has its own luminance management system

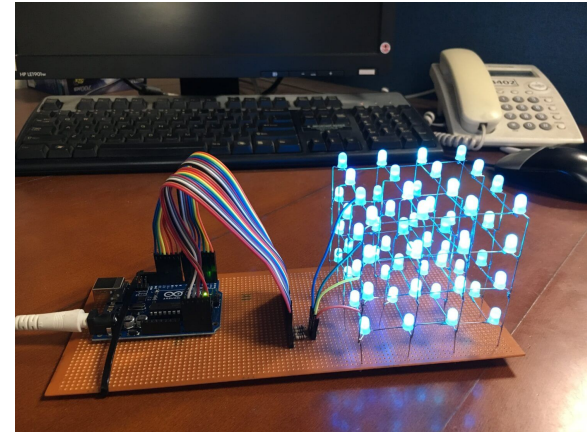

By selectively turning on and off certain ceiling lights

Thank you

:>]