

## Transitions - habitat for Troll research station

Group 1: Iris Claus, Daphne Kamsteeg, Ludovica Perone Pacifico, Chloé Phan, Marieke van Wijk

Tutors: Henriette Bier, Arwin Hidding

<sup>1</sup> Affiliation (Department of Architecture, Faculty of Architecture and the Built Environment, Delft University of Technology, MSc Architecture Urbanism and Building Sciences)

### Abstract

This research shows how a Voronoi-based design can improve how two people share a compact space under extreme conditions where natural light is unreliable. These circumstances lead to both spatial and psychological challenges. For example, the lack of privacy, static layouts and disrupted circadian rhythms. The Voronoi-based spatial logic is introduced to create flexible and efficient spatial divisions that adapt to different activities. The design is based on collective, private and semi-private modes, enabling dynamic transformations of the space through foldable walls. These spatial configurations act as triggers for an intelligent lighting system. The lighting system is developed using a three-layer control structure consisting of activity (what is the user doing?), identity (who is where in the container), and environmental context (how are the weather conditions outside?). The system integrates wearable technology (smart watches) and sensors to respond to user presence, behavior and biological data. To give users control over their own preferences, the smartwatch has manual slides that allow users to override the automatic lighting settings at any time. To ensure long-term well-being the system has a safeguard system. If a user selects lighting conditions outside healthy ranges a red warning is displayed. The system initiates a corrective fade, gradually returning to healthy light levels over 30 minutes. This creates a balance between freedom and guidance. Additionally, machine learning is implemented to recognize patterns in the physiological data. Combining this with the weather data machine learning is able to predict the values of the Illuminance and the CCT for the lighting design in the container. The project concludes with a fully integrated system where spatial transformation and intelligent lighting work together to support well-being, productivity, and adaptability in extreme environments.

**Keywords:** Collective versus Private modes, Spatial configurations, Adaptive lighting, Voronoi design, Machine learning

## 1 Introduction

Living in extreme conditions is very challenging, especially when two people must share a compact, enclosed space for an extended period. Both users can have different daily rhythms, preferences and needs or one person can be sick, which can lead to conflicts if the space and its facilities are not designed to accommodate them. Limited access to natural light can affect both mental health and circadian rhythms. Regular static spatial layouts fail to account for overlapping or conflicting activities. As a result, users are forced to compromise, which can lead to discomfort and inefficient use of space.

This project explores how a living environment can better respond to these challenges. It proposes a dynamic and adaptive system that enables multiple users with different preferences to share a limited space without hindering one another. The design is based on Voronoi spatial logic, which creates an organic and efficient division of space while minimizing unused areas. Unlike traditional, rigid layouts, this approach ensures that the environment is easily adaptable to different activities, thereby supporting both shared and individual use.

The key aspect of this design is the integration of spatial organization with an intelligent lighting system that responds to the user's identity, activity and environmental context. By recognizing individual preferences and biological rhythms, the system enables personalized conditions within a shared environment. In addition, the design addresses privacy by allowing users to temporarily define and enclose their own zones when needed. Over time, the system evolves through machine learning, enabling it to predict users' needs and optimize lighting conditions. The goal of this design is to develop a responsive environment that promotes well-being, supports both users with diverse needs and rhythms and enables them to live together comfortably.

The goal of this design is to create a responsive environment that promotes well-being and supports multiple users with diverse needs, enabling them to live together comfortably under extreme conditions. To ensure the system performs under the most demanding circumstances, the project is developed around a worst-case scenario: an emergency situation in which researchers are confined to the container due to extreme weather, while following opposing daily schedules during Arctic winter and summer. This represents the highest level of spatial and functional stress, requiring maximum flexibility, adaptability, and separation of activities. Designing for this extreme ensures the system can easily accommodate less demanding scenarios.

## 2 Research Methodology

### 2.1 Design

The design concept draws from two main references: Scott Snibbe's Boundary Functions, which views personal space as dynamic and context-dependent [1]; and The End of Sitting by RAAAF [2], which employs Voronoi geometries as a method for adaptive spatial systems.

Together, these references support a design approach focused on variation and spatial flexibility, see figure 1.

## TRANSITIONS

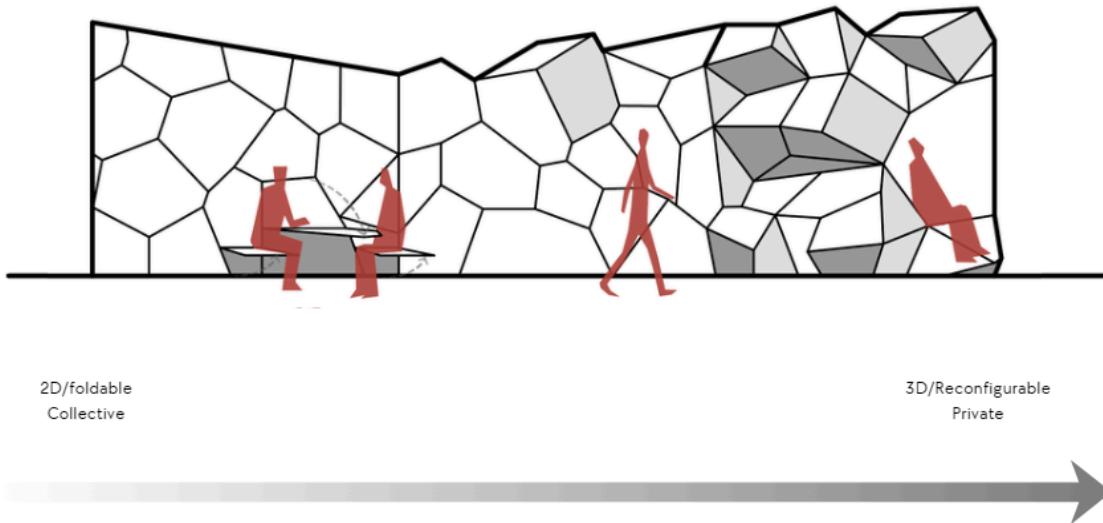
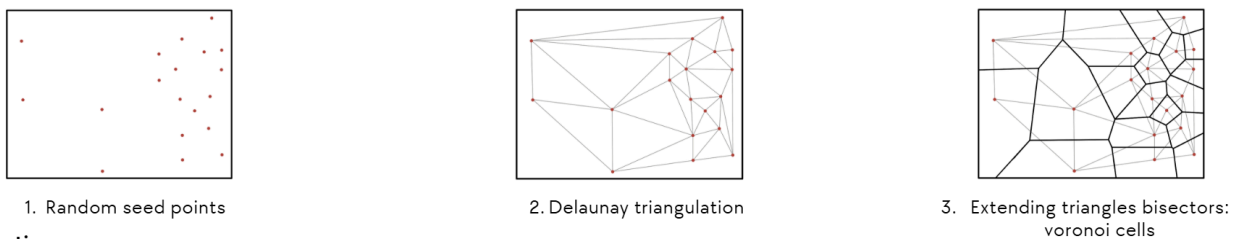

**Figure 1:** Concept diagram

The design was informed by an investigation into: the geometric properties of Voronoi geometry (ensuring that the Voronoi-based approach is not merely an aesthetic addition, but a fully integrated core element and a primary strength of the project), the functional requirements of the users, and the intrinsic relationship between the two.

### 2.1.1 Voronoi-based approach

Voronoi patterns are defined by a generative process consisting, as shown in figure 2, of three main stages: definition of seed points; connection of these seed points through minimal triangulation (Delaunay triangulation); construction of the perpendicular bisectors of the triangulation edges, extended until they intersect, forming the edges of the Voronoi cells.

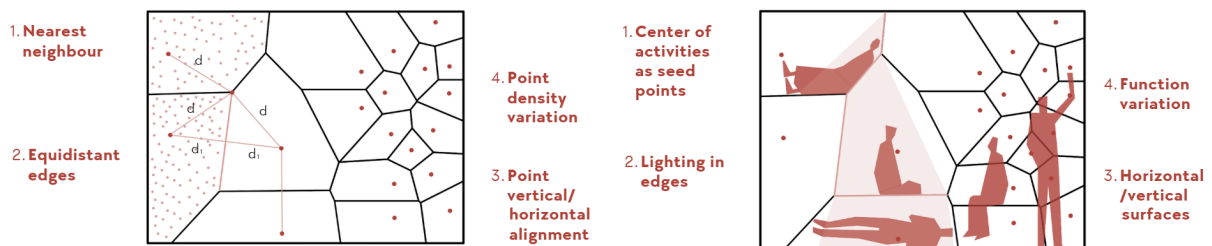

**Figure 2:** Voronoi generation process

The following key geometrical properties have been strategically integrated into the project design, for a visual presentation see figure 3..

- Nearest neighbor: each Voronoi cell consists of all points that are closer to its seed point than to any other. To ensure that cells adapt to specific human needs, the centroids of activity-based spatial regions (determined through activity mapping, as detailed in the following sections) were used as seed points.

- Equidistant edges: cell edges represent the set of points equidistant from the centers of the two adjacent cells they separate. LED strips were integrated along these edges to optimize light distribution across the interior.
- Horizontal and vertical alignment of points: aligning two seed points horizontally generates a perfectly vertical surface, and vice versa. This property enables the formation of functional architectural surfaces, such as tables and beds.
- Density-driven variation: variations in point density produce corresponding variations in cell size; higher concentrations of points result in smaller cells, while sparser distributions generate larger ones. This principle was used to accommodate functional gradients (from space-intensive activities such as sleeping and working to high-density, low-impact functions such as shelf storage) and to generate the transition from 3D to 2D geometries (further explained in the following section).



**Figure 3:** Voronoi properties as design strategies

Of the various ways Voronoi geometry can be configured, four were explored (see figure 4), each addressing a specific design principle or condition.

Voronoi geometry is inherently shape-independent, allowing both irregular and precise configurations. Irregular geometries justify its use as the project's generative principle, as they enable forms that closely adapt to their intended function, supporting ergonomic positioning of the human body for specific activities. Conversely, when seed points are precisely arranged, orthogonal configurations can be produced, allowing Voronoi geometry to align with the geometry of the container. While less effective ergonomically, these configurations are more efficient for storage.

Voronoi can exist in both 2D and 3D configurations. Two-dimensional Voronoi patterns maximize available floor area (crucial in highly constrained environments) and facilitate rapid reconfiguration, making them suitable for high-frequency activities. However, due to lower structural rigidity and reduced ergonomic comfort, they are primarily suited for temporary functions. In contrast, although more space-intensive, 3D Voronoi cells offer greater structural integrity and improved ergonomic adaptation, making them appropriate for permanent functions such as sleeping and specialized storage.

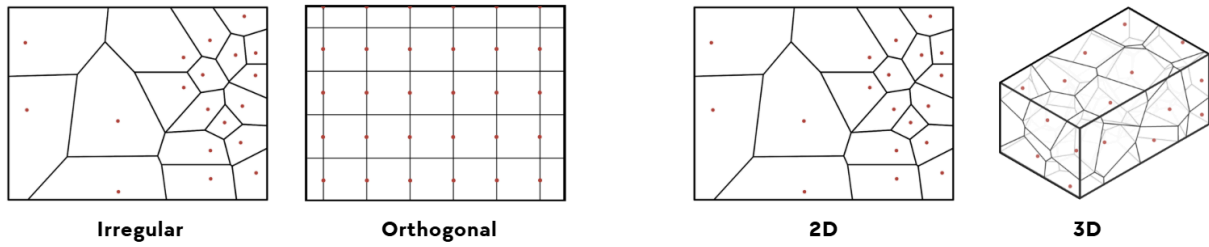

Figure 4: Voronoi configurations

### 2.1.2 Activity mapping

An activity mapping of all the activities taking place in the container (sleeping, working, eating, relaxing, and storage) allowed the identification of main differences in duration, frequency, and spatial requirements (See figure 5). Collective functions are concentrated in the center of the space, while individual functions are located along the edges. Additionally, some activities require both collective and private configurations, particularly under emergency conditions where privacy needs are highly variable.

Vertically, the majority of activities take place between 0.45 m and 2.10 m, allowing the upper and lower zones (“dead zones”) to be used for storage and technical functions, as shown in figure 6.

#### In time & space

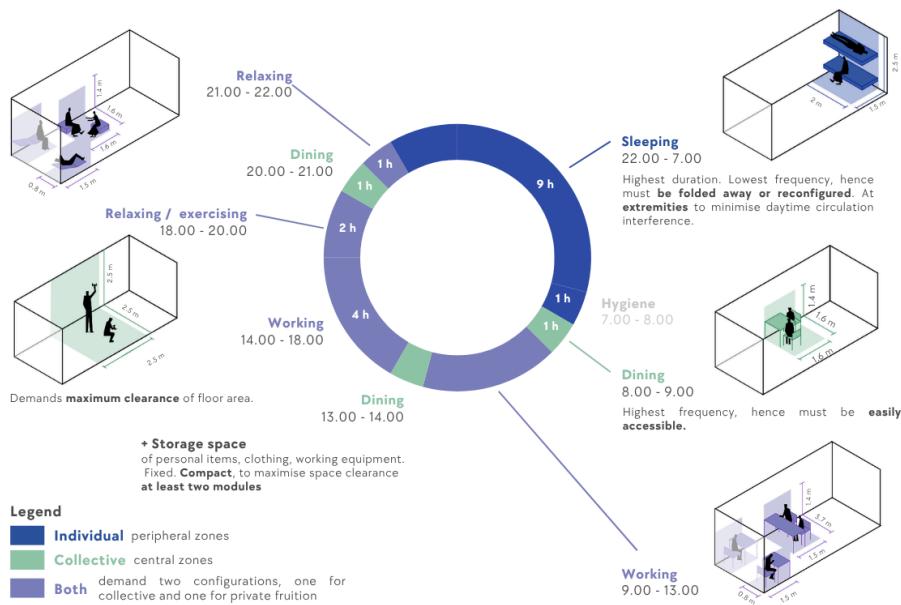

Figure 5: Activity mapping in time and space

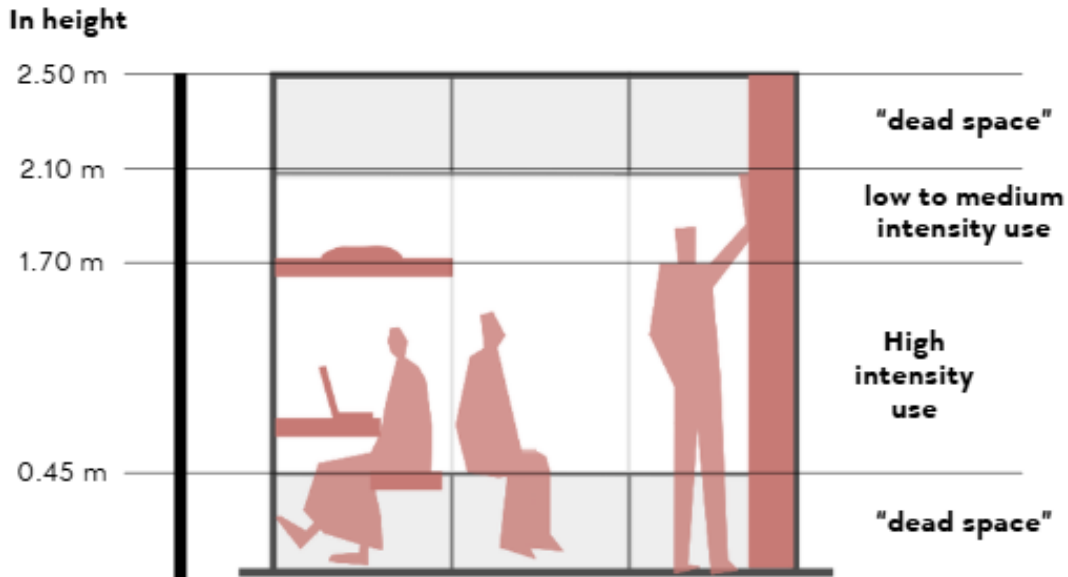

Figure 6: Activity mapping in height

### 2.1.3 Principles and process

Based on the findings of the research, the main design principles and generative steps of the project are the following, as illustrated in figure 7:

- storage in the corners: this principle leverages the orthogonal geometry of the container to maximize storage efficiency, while enabling a gradual transition toward more irregular and ergonomic zones;
- width-based zoning: activities are distributed along the container walls from wider to narrower spatial requirements. This strategy enables the integration of the two opposing configurations—3D and 2D—within a continuous spatial gradient.
- boundary reconfigurability: two-dimensional surfaces function as adaptable partitions, enabling transitions between collective, private, and semi-private spatial configurations according to user preferences.

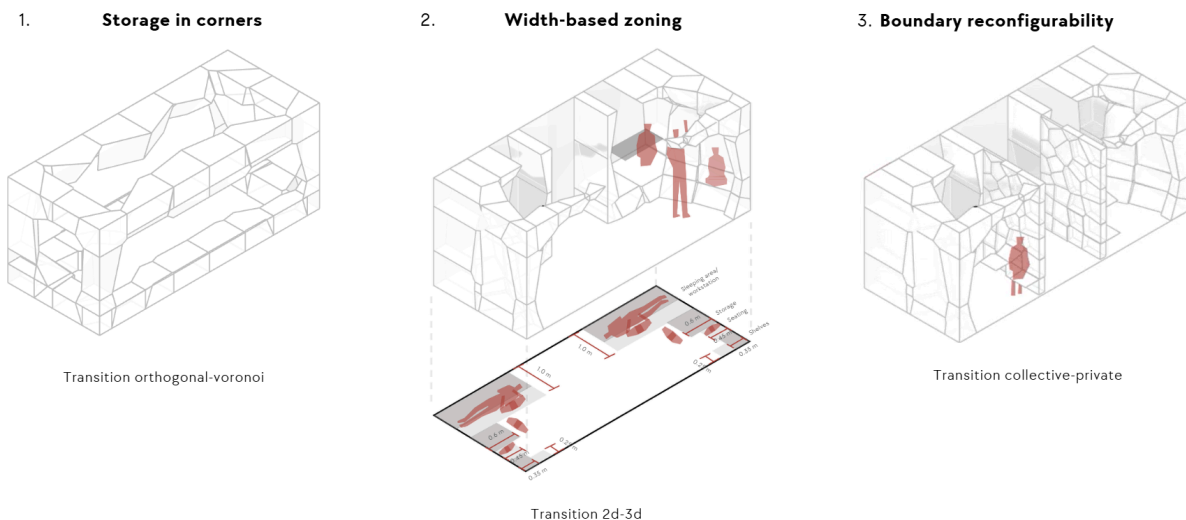

Figure 7: Design principles and process

### 2.1.4 Grasshopper workflow

The computational generation of the project followed a structured Grasshopper workflow (see figure 8 and 9).

- The plan and 4 cross sections were generated through manual manipulation of 2d-voronoi seed points, to control both the transition between the two walls (2D to 3D) and the shift from the orthogonal storage perimeter to the irregular, ergonomic central zones.
- Additional points were distributed across walls, ceiling, and floor to locally increase density where needed. Some were precisely positioned to control the alignment and dimensions of specific elements, such as the dining table and seating. Random points were introduced to complete the spatial distribution, followed by a manual refinement process to ensure they did not interfere with the intended 2D–3D transitions.
- The complete set of points (section seed points and additional points, the plan was only generated as reference for the sections) was used to generate a unified three-dimensional Voronoi geometry, resulting in a single integrated architectural system.

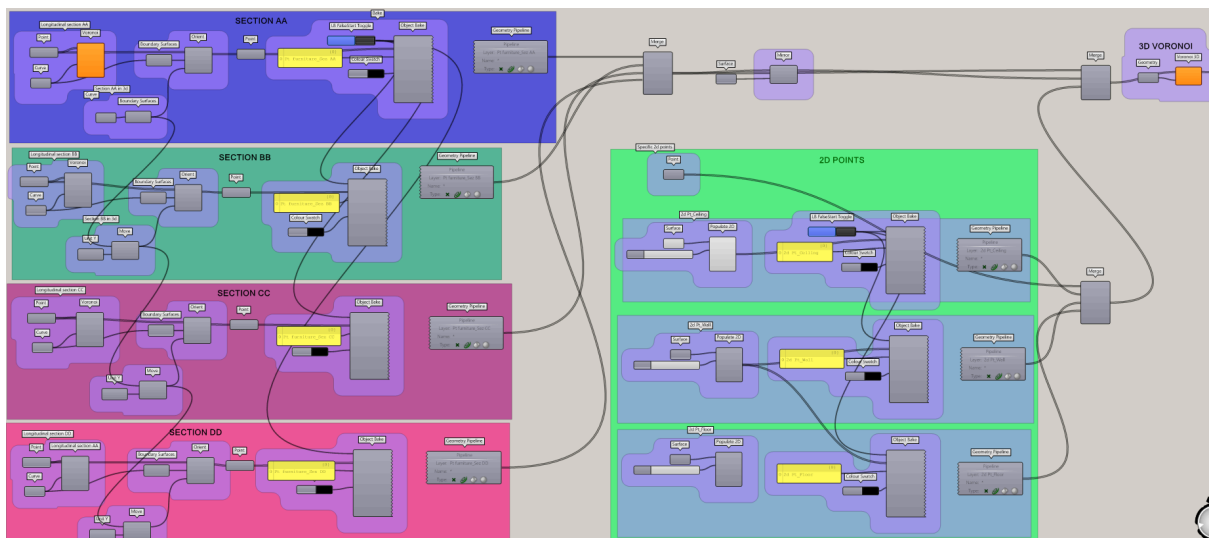

Figure 8: Grasshopper script

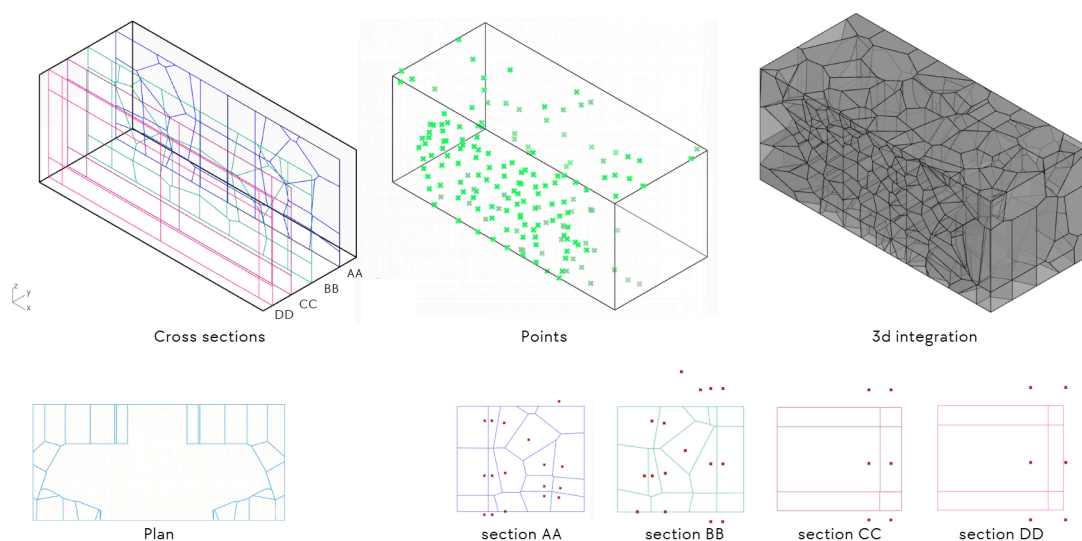

Figure 9: Grasshopper generated geometry

The design created an integrated spatial structure that supports flexible use of the container. The possible design configurations are shown in figure 10.

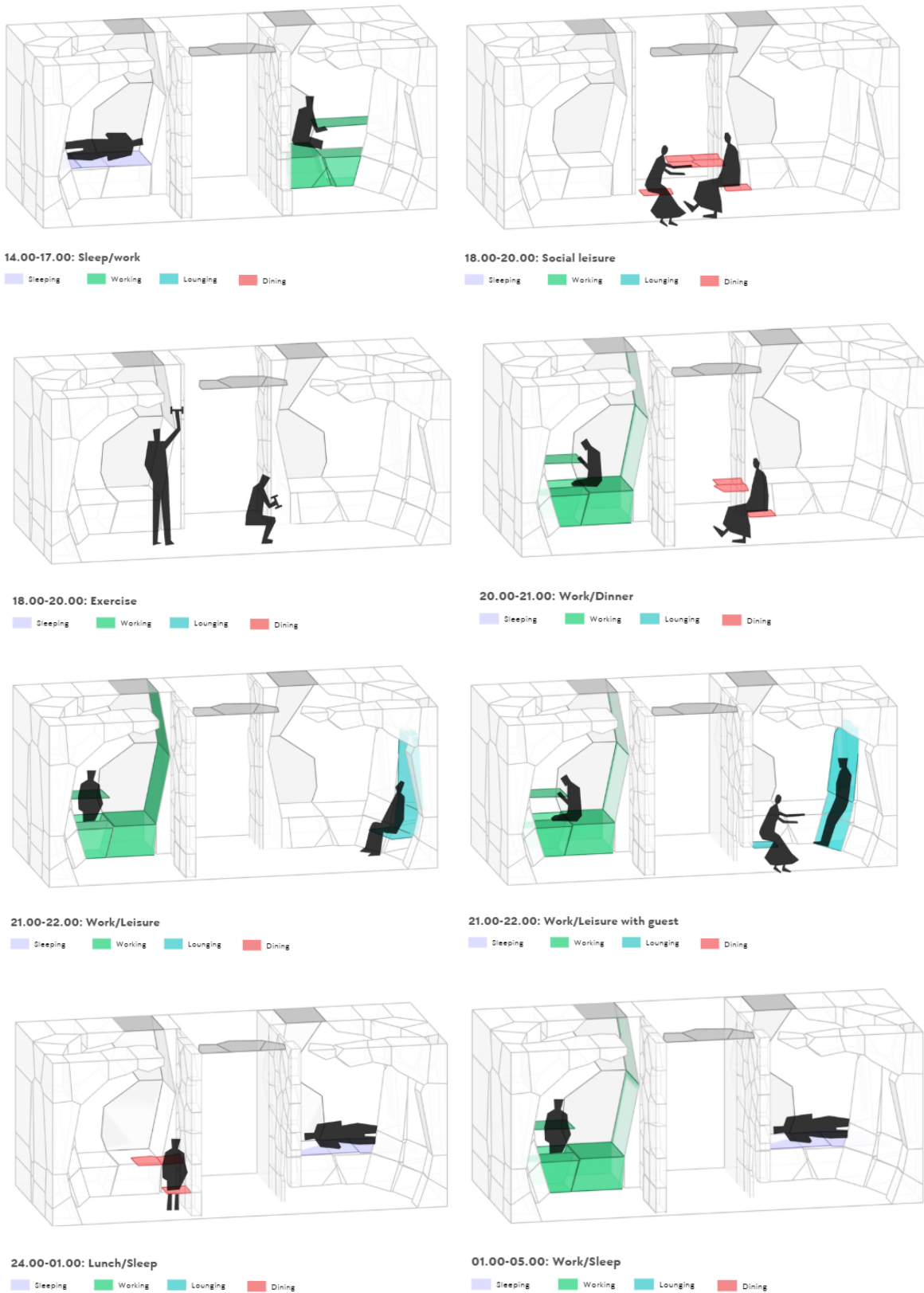
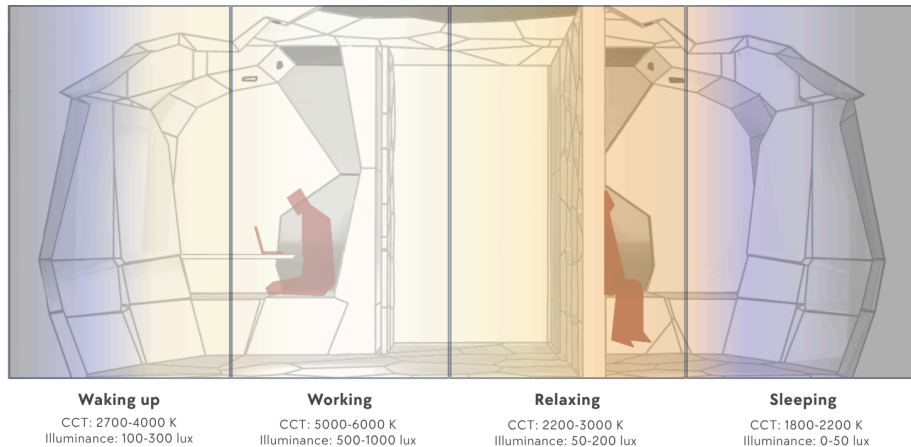

Figure 10: Design configurations

## 2.2 Lighting principles

Light is one of the three core principles of the design, as it directly influences well-being, orientation, and spatial perception in extreme Arctic conditions. In this project, light is not an addition, but an integral system that supports daily life. Sources used for the researched on which the lighting principles were build are [3], [4], [5] and [6].

The lighting design is based on a circadian system that adjusts both intensity (lux) and color temperature (CCT) over a 24-hour cycle. Cool, bright light supports work and activity, while warm, dimmed light promotes rest and sleep, as shown in figure 11.



**Figure 11:** *Circadian rhythm*

The system consists of three layers: primary lighting (constant basic lighting), secondary lighting (task-, ambient-, and natural lighting depending on activity), and tertiary lighting (navigation and emergency lighting). A visual representation of this is shown in figure 12. This hierarchy ensures a balance between stability and flexibility.

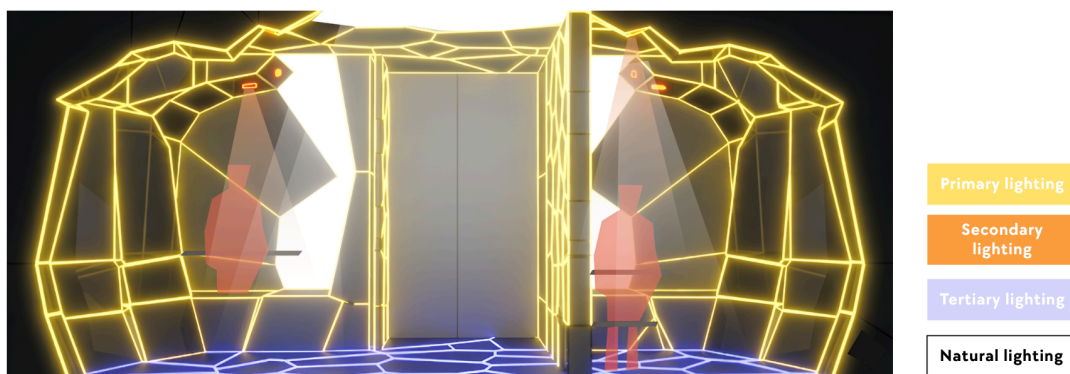

**Figure 12:** *Lighting layers*

As illustrated in figure 13, natural light is used as input for the system, but is always regulated. In situations with extremely high light levels (such as the midnight sun), it is filtered, while in low-light conditions (polar night), artificial light compensates for the deficiency. This keeps the indoor climate stable with a target value of approximately 500–750 lux.

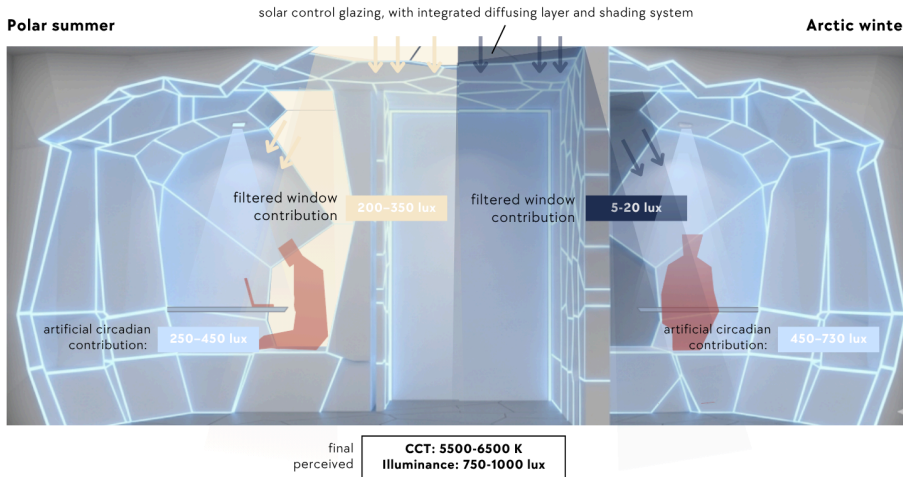

Figure 13: Natural lighting integration

In addition, each spatial configuration is linked to a lighting character: active and social situations are brighter and higher in contrast. At the same time, private and restful moments are illuminated with warmer, softer light.

### 2.3 Lighting control systems

The lighting system is designed to provide adaptive and personalized lighting in a compact and shared environment. To manage multiple users, activities and external conditions, the system is structured into three layers of intelligence: *activity*, *identity*, and *environmental context* (as depicted in figure 14).

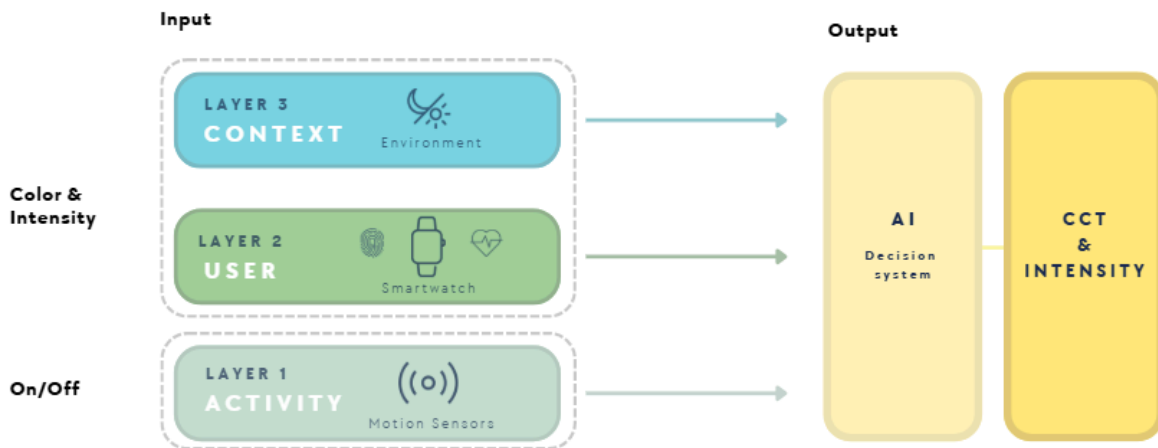

Figure 14: Layers of intelligence

The first layer, identity, recognizes who is in the room and where that person is, using smartwatches as identity keys. These smartwatches provide data about user location, preferences such as light intensity and color temperature and biological data such as heart rate. This input enables personalized lighting conditions.

The second layer is activity. This layer interprets user behavior through motion sensors and spatial transformations. To limit system complexity, the decision was made to keep the number of integrated technologies as small as possible. In an earlier design phase, computer vision was considered as the

overarching system instead of motion sensors. However, this approach proved unsuitable, as motion sensors were still needed to detect movement in the dark. In addition, this system turned out to be too slow and too sensitive to interpretation errors. For these reasons, a motion sensor-based solution was ultimately chosen, which responds faster, is more reliable, and functions effectively even during night. For example, nighttime movement activates navigating lighting, while unfolding furniture signals specific activities such as working or shared use. These inputs are directly linked to corresponding lighting scenarios. Additionally, biological data such as increased heart rate can trigger adjustments, for instance, shifting to warmer tones to support relaxation.

The last layer, environmental context, integrates external data, such as weather and seasonal light patterns. This allows the system to compensate for the absence of daylight during polar night or the continuous daylight during midnight sun and maintain a healthy lighting rhythm in extreme environments.

Within this layered structure, the activity layer is responsible for switching the light on/off functioning as the systems trigger mechanism. The other layers, identity and environmental context, define how the lighting is expressed, shaping parameters such as illuminance and color temperature based on user preferences and external conditions. Together, these layers ensure lighting behavior that is both responsive to user actions and tailored to individual and environmental needs.

Although the system is highly automated, users stay in control through manual overrides via the smartwatch. A safeguard mechanism is implemented to ensure healthy lighting conditions by warning users and gradually correcting extreme settings, as illustrated in figure 15.

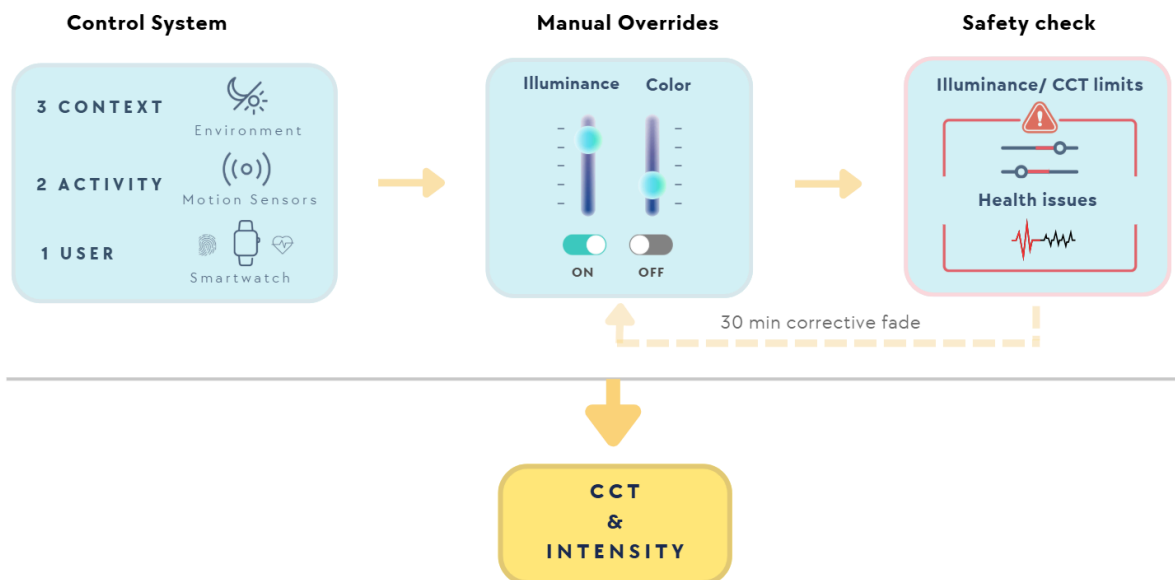

**Figure 15:** Manual overrides

## 2.4 Machine learning

To achieve an integrated lighting design that reacts to the environmental and physiological circumstances we use machine learning. Machine learning, unlike AI, infers patterns from data while AI needs the patterns as an input. This transforms the system from reactive to predictive.

The operating system used for this is Jupyter Notebook, as explained in the lecture from Lisa-Marie Mueller [7]. It is used to train a model that produces the prediction of the values of the illuminance and the CCT. The model uses neural networks. First, features are selected and the model from Lisa-Marie Mueller is trained, so that the lighting system can be optimized to the researchers needs and actions. The features are the input variables, possible features;

- Weather features; outdoor\_temp, direct\_normal\_radiation, rel\_humidity, diffuse\_normal\_radiation, global\_horizontal\_radiation, infrared\_radiation, direct\_normal\_illumination, diffuse\_horizontal\_illumination, global\_horizontal\_illumination, total\_sky\_cover.
- Physiological features; hrv\_rmssd\_ms, heart\_rate\_bpm, pupil\_mm, blink\_rate\_per\_min, skin\_conductance\_uS, respiratory\_rate\_bpm.

The labels are the output values, in this case the predicted illuminance\_lux and cct\_kelvin.

The features are grouped according to a feature correlation heatmap, see figure 16. Features with a high correlation of  $>0.8$  with each other may be redundant, so they can be grouped or dropped. Furthermore, features with high correlation with labels are likely strong predictors. These groups, see figure 17, will then be plot against illuminance and CCT, the scatter plots.

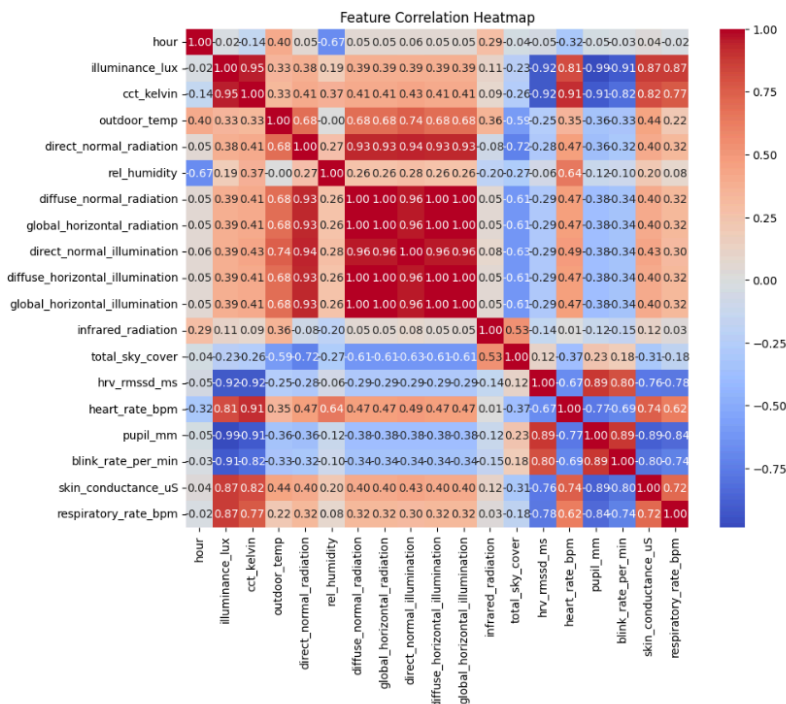

Figure 16: Feature correlation heatmap

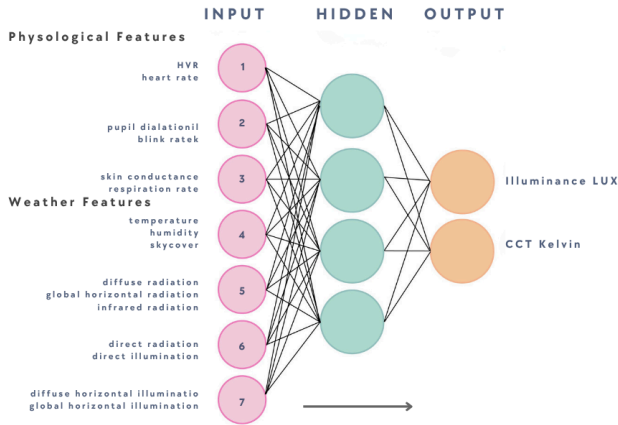

Figure 17: Feature groups, before dropping features

Scatter plots are used to group features and filter out redundant ones. This ensures that the model is accurate without risk of overfitting. Overfitting creates noise in the model, making the predictions of the values unreliable. See figure 18 and 19.

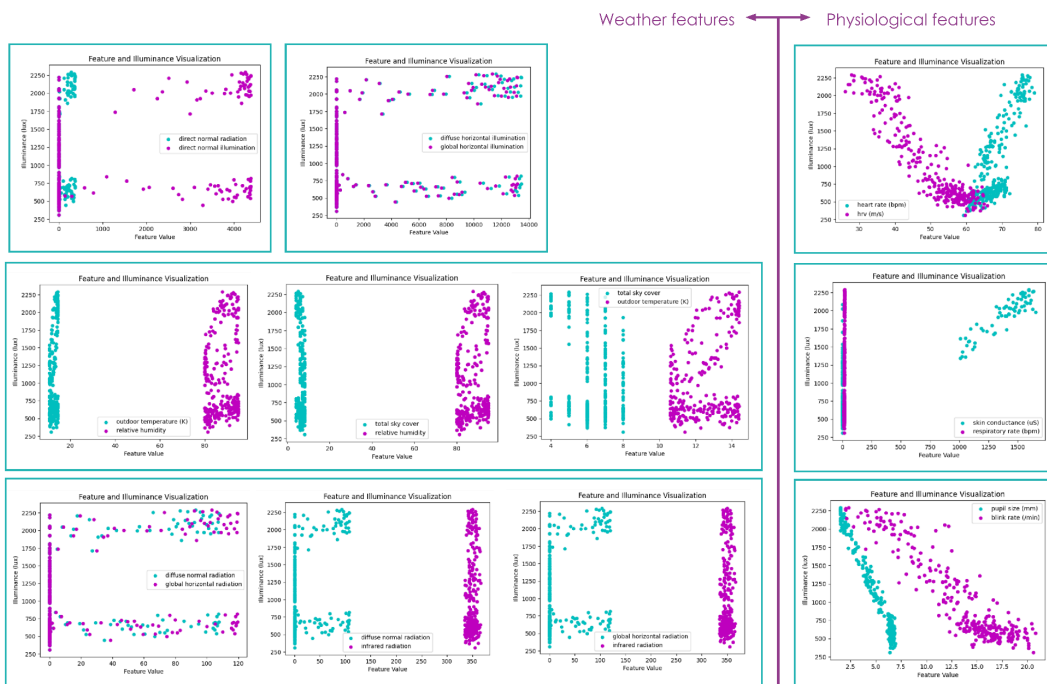

Figure 18: Scatter plots, Illuminance

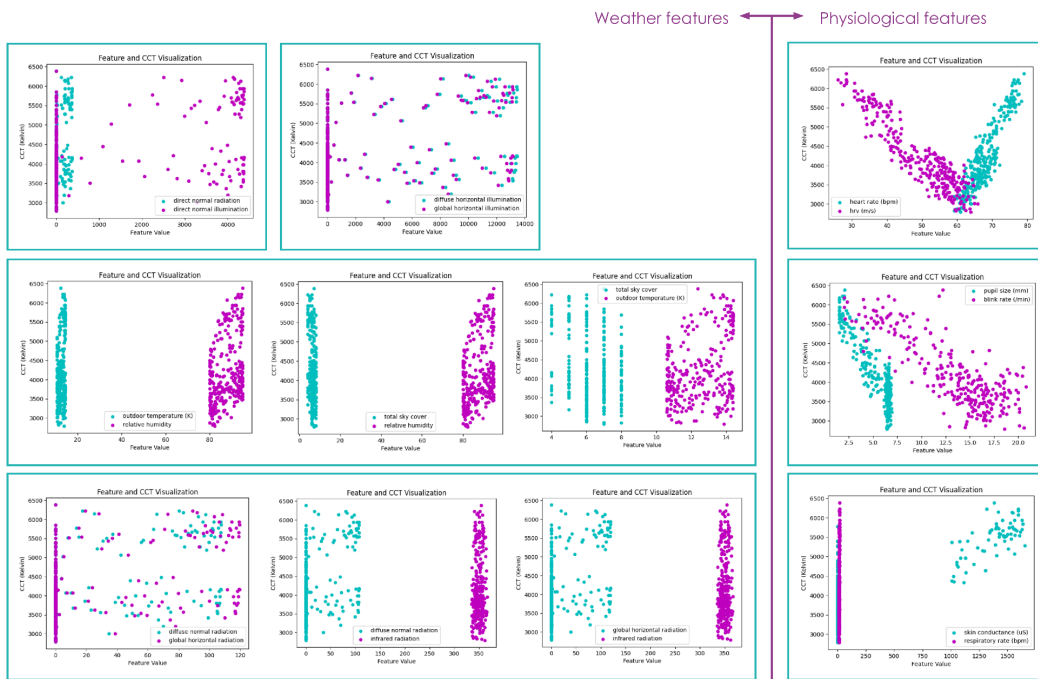

Figure 19: Scatter plots, CCT

From the scatter plots there can be concluded to drop the following features;

- direct\_normal\_illumination (extremely correlated with direct\_normal\_radiation, they measure the same physical phenomenon in different units)
- global\_horizontal\_illumination and diffuse\_normal\_radiation (both extremely correlated with diffuse\_horizontal\_illumination, they all represent scattered light in the atmosphere)
- pupil\_mm (indicates stress like skin\_conductance\_uS, but pupil size is noisier and light dependent)

The remaining features are kept and grouped. See figures 17 and 20 for a comparison.

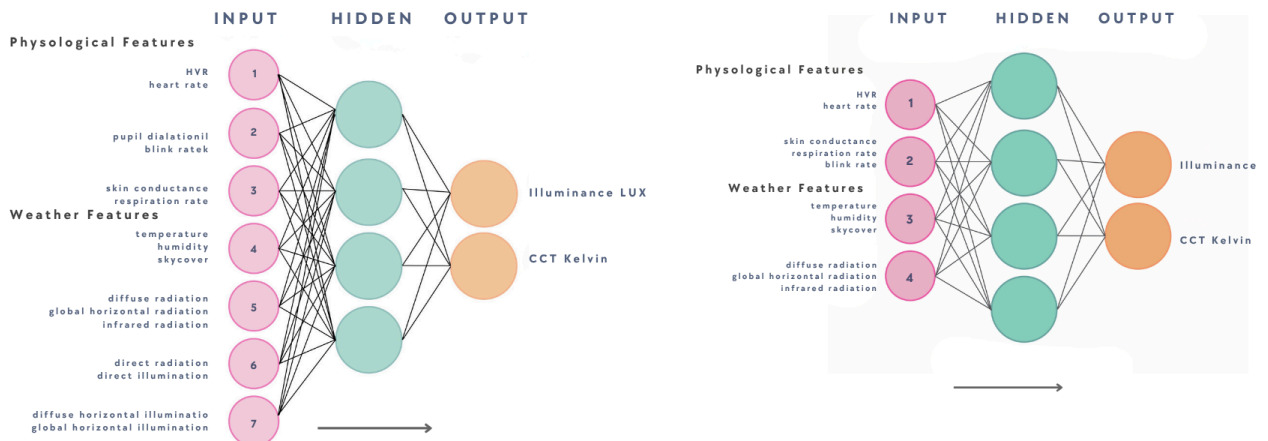

Figure 17 and 20: Feature groups before (left) and after (right) dropped features, final selection

The model was trained with the selected feature groups. To see if this selection made a positive impact, the performance of the first model was compared to the second model trained with adjusted features. This comparison was done by evaluating the model performance. The R-square is used to evaluate how well the model represents the data in %. Secondly, error functions such as RMSE and MAE provide information about how far off the estimation is from the actual value. RMSE penalizes large errors, and MAE takes the average. Both are relative to the scale of the dataset.

The value of the evaluations is as follows;

Illuminance

- R-square = 75,4% → 96,1%
- RMSE = 292.06 → 116.67
- MAE = 239.49 → 93.74

CCT

- R-square = 27,5% → 80,2%
- RMSE = 761.90 → 397.62
- MAE = 321.18 → 239.49

For both the illuminance and the CCT, the % of R-square increases, so the representation of the model does as well. The RMSE and MAE both decrease, meaning that there are less errors in the model.

In conclusion, there is a clear improvement of the model performance. With this model the Illuminance and CCT values are predicted for the lighting design in the container.

For directing the lighting system, the Jupyter model should be combined with the e.g. Arduino. For a prototype this would be a good fit to direct the LED lights [8]. In the actual case, Dali could be used, which is more reliable and uses individual fixture addressing. A possible setup for the Arduino prototype is shown below, see figure 21.

#### Arduino prototype setup

Jupyter code

```
[ ]: import serial
import time

ser = serial.Serial('COM3', 9600)
time.sleep(2)

def send_values(warm, cold):
    message = f'{warm},{cold}\n'
    ser.write(message.encode())

# test
send_values(200, 50) # warm Licht
send_values(50, 200) # koud Licht
send_values(150, 150) # neutral
```

Arduino code

```
1 String inputString = "";
2 char inputChar;
3 const int serialIn = 10;
4 const int serialOut = 11;
5
6 void setup() {
7   Serial.begin(9600);
8   pinMode(serialIn, INPUT);
9   pinMode(serialOut, OUTPUT);
10 }
11
12 void loop() {
13   if (Serial.available()) {
14     inputString = Serial.readStringUntil('\n');
15     int commandIndex = inputString.indexOf(",");
16     int warm = inputString.substring(0, commandIndex).toInt();
17     int cold = inputString.substring(commandIndex + 1, toInt());
18
19     warm = constrain(warm, 0, 255);
20     cold = constrain(cold, 0, 255);
21     analogWrite(serialOut, warm);
22     analogWrite(serialOut, cold);
23   }
24 }
25
26 + calculate warm_pwm and
27 cold_pwm
```

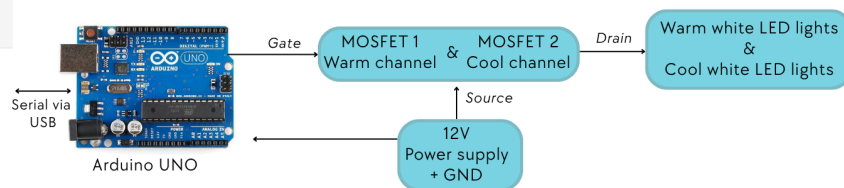
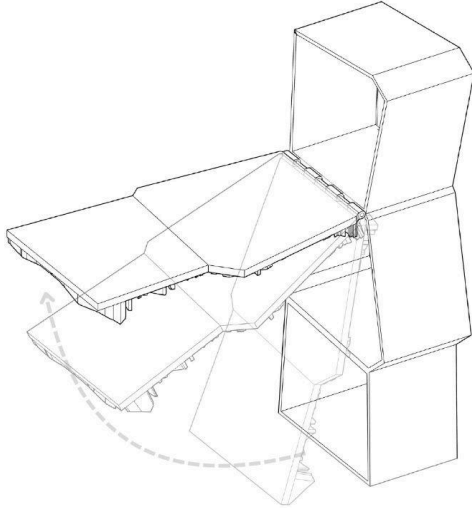

Figure 21: Lighting prototype setup

## 2.5 Prototype

For the prototype, a fragment of the design was selected, as shown in figure 22: the table that transforms from a vertical storage position against the wall into a horizontal usable surface. This fragment was selected because it combines several key aspects of the project: geometry, movement, structure, and the integration of technical systems. It allows us to test how complex Voronoi logic can become functional and livable.



**Figure 22:** Selected fragment of the design

The table rotates 90 degrees via an integrated hinge mechanism, specially designed for 3D printing and reinforced with a metal shaft. The movement is limited to two positions (open and closed) and can optionally be motorized using an Arduino system, with the motor integrated into the fixed structure. See figure 23 for the hinge mechanism.

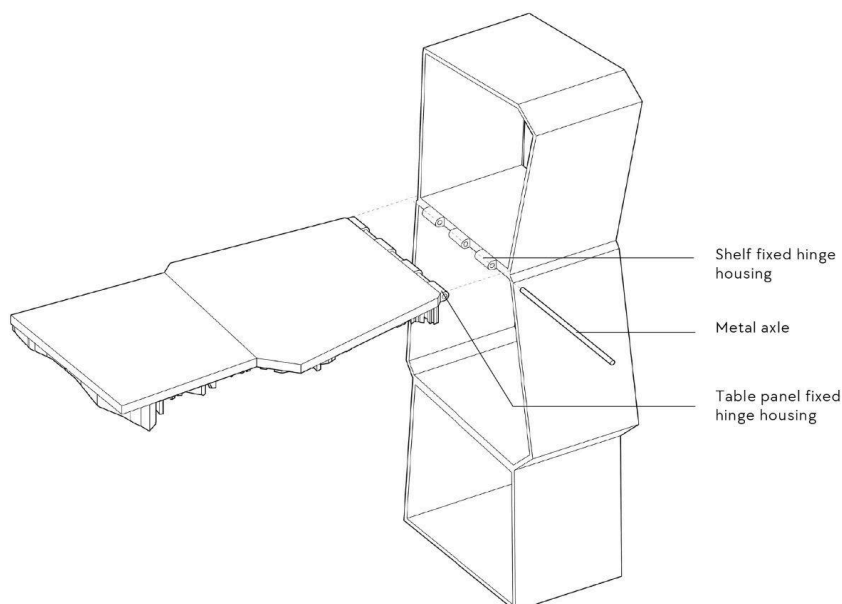

**Figure 23:** Hinge mechanism

Structurally, the element is strengthened by a Voronoi rib structure, optimized with Karamba, where the density increases around the hinge for extra stability and force distribution, as shown in figure 24. The prototype is produced via robotic 3D printing with a KUKA arm, which enables complex and integrated geometries.

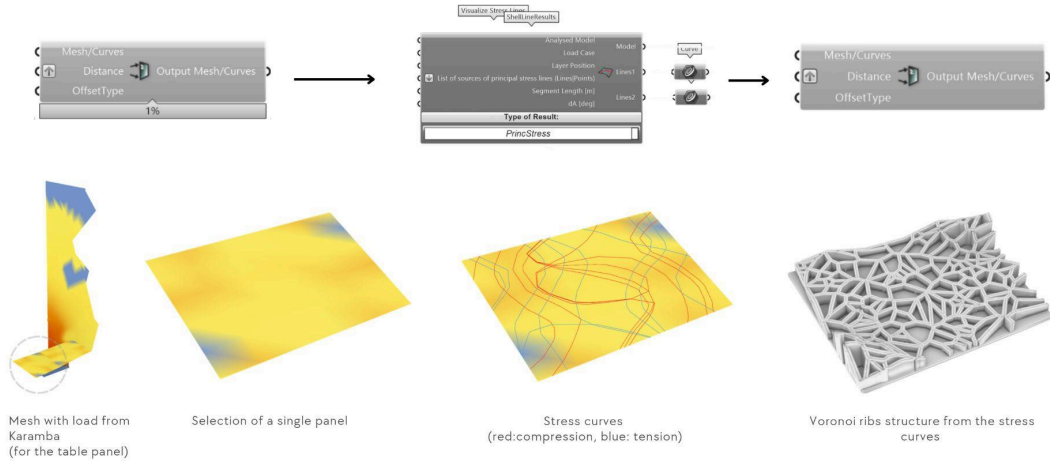

**Figure 24:** Structural optimization

Recycled PET filament was chosen as the material due to its sustainability, lightness, and suitability for additive manufacturing. See figure 26. LED lighting is integrated into the Voronoi structure and provides indirect, diffused light.

The prototype demonstrates how the table is not a separate object, but a functional transformation of the Voronoi structure in which geometry, movement, and technology converge into a single system. Figure 25 illustrates the use of the prototype.



**Figure 25:** Prototype render and use scenario

## 2.6 Integrated design

Now that all design elements are explained, they are brought together in three renders.

The first render shows the collective configuration, with the dining table unfolded and the lighting balanced between both users' preferences. If one person's heart rate increases, the lighting shifts to warmer tones to help them calm down. See figure 26.



**Figure 26:** *Render collective configuration*

The second render presents a semi-private configuration. Motion sensors detect that one wall is unfolded. The smartwatches registrate low heart rates for both users, with one so low that the system identifies this person as sleeping, leaving that side of the room completely dark. See figure 27.



**Figure 27:** *Render semi private configuration*

The final render illustrates the private mode, where both walls are unfolded. The system detects that the previously sleeping person has gotten out of bed and activates navigation lighting. Meanwhile, the other person is working with high focus, so the lighting shifts to a cooler tone. See figure 28.



**Figure 28:** *Render private configuration*

### 3 Conclusions

This research demonstrates the potential of an adaptive living environment that integrates spatial flexibility with intelligent lighting to support two occupants sharing a compact space under extreme conditions. The main outcome of the study is the development of a responsive system in which spatial configurations and lighting behavior are interconnected, allowing the environment to dynamically adjust to user identity, activity, and environmental context.

By applying a Voronoi-based spatial logic combined with foldable elements, the design enables smooth transitions between collective and private modes, reducing spatial conflicts and improving both functionality and psychological comfort. The integration of a three-layer lighting control system, supported by wearable watches and sensors, allows for personalized lighting conditions that respond to physiological signals and behavioral patterns. Furthermore, the incorporation of machine learning enhances the system by enabling predictive adjustments of illuminance and CCT based on both environmental and physiological data, significantly improving accuracy and performance over time.

The importance of this work lies in its integrated approach, where spatial design and technological systems are not treated as separate components but as a unified framework. It promotes the well-being and productivity of the researchers. Which is important because of the limited or absent natural light, so maintaining circadian rhythms and personal comfort is critical.

However, several limitations should be acknowledged. The system relies on the availability and accuracy of sensor data and wearable technology, which may introduce uncertainties or technical dependencies. Additionally, the machine learning model is based on selected features and controlled datasets, which may limit its generalizability to more complex real-world scenarios like the actual case. The prototype development focuses on the table, a single spatial element, meaning that the full system integration has not yet been physically validated at scale.

Future applications of this research include the development of fully operational prototypes and the expansion of the system to larger and more diverse environments. Further research is recommended to improve model generalizability, explore user acceptance, and investigate long-term behavioral adaptation. Overall, this study provides a foundation for designing intelligent, adaptive living environments that can enhance human well-being in spatially constrained and extreme conditions.

#### 3.1 Study Limitations

The design is based on a hypothetical worst-case scenario and does not have long-term real-world validation, so actual user behavior and system performance remain uncertain.

Other study limitations are results of the fact that we can not test it in the environment of the case over a longer period of time. For example, the system relies on sensors and wearable devices, which may introduce inaccuracies due to measurement errors or data loss. Furthermore, technical aspects such as system latency, energy use, and long-term maintenance are not fully addressed, and there is no extensive user testing to validate psychological and experiential outcomes.

## Acknowledgements

We would like to thank Vera Laszlo, education assistant, for support during this course. We also thank the other students who participated in this course for their inspiration and valuable contributions.

## References

- [1] S. Snibbe, "Boundary Functions," Snibbe.com, 1998. Access online on 15 April 2026 at <https://www.snibbe.com/projects/boundary-functions/>
- [2] RAAAF, "The End of Sitting," RAAAF.nl, 2014. Access online on 15 April 2026 at [https://www.raaaf.nl/en/projects/726\\_the-end-of-sitting/](https://www.raaaf.nl/en/projects/726_the-end-of-sitting/)
- [3] InnerScene, "Circadian Sky Color Temperature Range," InnerScene.com. Access online on 15 April 2026 at <https://www.innerscene.com/SpecHelp/CircadianSky/cct>
- [4] Y. Zhu, M. Yang, Y. Yao, X. Xiong, X. Li, G. Zhou, and N. Ma, "Effects of Illuminance and Correlated Color Temperature on Daytime Cognitive Performance, Subjective Mood, and Alertness in Healthy Adults," *Environment and Behavior*, vol. 51, no. 2, pp. 199-230, 2019. DOI: [https://www.researchgate.net/publication/320692794\\_Effects\\_of\\_Illuminance\\_and\\_Correlated\\_Color\\_Temperature\\_on\\_Daytime\\_Cognitive\\_Performance\\_Subjective\\_Mood\\_and\\_Alertness\\_in\\_Healthy\\_Adults](https://www.researchgate.net/publication/320692794_Effects_of_Illuminance_and_Correlated_Color_Temperature_on_Daytime_Cognitive_Performance_Subjective_Mood_and_Alertness_in_Healthy_Adults)
- [5] Jarvis Lighting, "Color Temperature (CCT) Guide for Commercial LED Lighting," JarvisLighting.com, Mar. 2026. Access online on 15 Apr. 2026 at [https://www.jarvislighting.com/blogs/jarvis-lighting-insights/color-temperature-cct-guide-commercial-lighting?srsId=AfmBOoohYH4U-efn4WFrop0zclpRIN\\_Ob4Ay8F-18WTdhh-fBg50x2MI](https://www.jarvislighting.com/blogs/jarvis-lighting-insights/color-temperature-cct-guide-commercial-lighting?srsId=AfmBOoohYH4U-efn4WFrop0zclpRIN_Ob4Ay8F-18WTdhh-fBg50x2MI)
- [6] LED Light Expert, "How to Choose the Right Color Temperature for Different Spaces," LEDLightExpert.com, Aug. 14, 2025. Access online on 15 Apr. 2026 at [https://www.ledlightexpert.com/how-to-choose-the-right-color-temperature-for-different-spaces?srsId=AfmBOopcUM6fn-FaZkRs\\_Xdk3oEtswDcRJ-5cqmQsZRAJrrN8hQPzV6A](https://www.ledlightexpert.com/how-to-choose-the-right-color-temperature-for-different-spaces?srsId=AfmBOopcUM6fn-FaZkRs_Xdk3oEtswDcRJ-5cqmQsZRAJrrN8hQPzV6A)
- [7] L.-M. Mueller, "Applying Machine Learning for Lighting Design," Lecture, TU Delft, Delft, Feb. 27, 2026.
- [8] D. K. Rath, "Arduino based: Smart light control system," *International Journal of Engineering Research and General Science*, vol. 4, no. 2, pp. 784-790, 2016.